

Vesuvio 4 IP

User Manual



Model ID: VESUVIO4IP

CHAUVET
PROFESSIONAL

Edition Notes

The Vesuvio 4 IP User Manual includes a description, safety precautions, installation, programming, operation, and maintenance instructions for the Vesuvio 4 IP as of the release date of this edition.

Trademarks

Chauvet, Chauvet Professional, the Chauvet logo, Vesuvio, and Vesuvio 4 IP are registered trademarks or trademarks of Chauvet & Sons, LLC (d/b/a Chauvet and Chauvet Lighting) in the United States and other countries. Other company and product names and logos referred to herein may be trademarks of their respective companies.

Copyright Notice

The works of authorship contained in this manual, including, but not limited to, all designs, text, and images are owned by Chauvet.

© Copyright 2026 Chauvet & Sons, LLC. All rights reserved.

Electronically published by Chauvet in the United States of America.

Manual Use

Chauvet authorizes its customers to download and print this manual for professional information purposes only. Chauvet expressly prohibits the usage, copy, storage, distribution, modification, or printing of this manual or its content for any other purpose without written consent from Chauvet.

Document Printing

For best results, print this document in color, on letter size paper (8.5 x 11 in), double-sided. If using A4 paper (210 x 297 mm), configure the printer to scale the content accordingly.

Intended Audience

Any person installing, operating, and/or maintaining this product should completely read through the guide that shipped with the product, as well as this manual, before installing, operating, or maintaining this product.

Disclaimer

Chauvet believes that the information contained in this manual is accurate in all respects. However, Chauvet assumes no responsibility and specifically disclaims any and all liability to any party for any loss, damage, or disruption caused by any errors or omissions in this document, whether such errors or omissions result from negligence, accident, or any other cause. Chauvet reserves the right to revise the content of this document without any obligation to notify any person or company of such revision. However, Chauvet has no obligation to make, and does not commit to make, any such revisions.

Document Revision

Go to www.chauvetprofessional.com for the latest version.

Revision	Date	Description
2	04/2026	Updated What Is Included section

TABLE OF CONTENTS

1. Before You Begin 1

 What Is Included 1

 Claims 1

 Text Conventions 1

 Symbols 1

 Safety Notes..... 2

 FCC Statement of Compliance 3

 RF Exposure Warning for North America and Australia..... 3

 Expected LED Lifespan..... 3

2. Introduction 4

 Features 4

 Product Overview 4

 Product Dimensions 5

3. Setup 6

 AC Power 6

 AC Plug 6

 Resetting the Breaker 6

 DMX Linking 7

 DMX Personalities 7

 Remote Device Management..... 7

 USB Software Update 7

 Mounting 8

 Orientation..... 8

 Rigging 8

 Procedure..... 8

4. Operation 9

 Control Panel Description 9

 Menu Map 9

 Starting Address..... 10

 DMX Channel Assignments and Values 10

 11Ch..... 10

 Standalone Configuration..... 11

 Interval Set 11

 Duration Set 11

 LED Color 12

 DMX 512 12

 Backlight Timer 13

 RDM 13

 Remote Setup 14

 Pairing..... 14

 Enabling and Disabling Remote Operation..... 14

 Clearing Paired Remotes..... 15

 Settings Configuration 16

 Error Messages..... 17

5. Maintenance..... 19

 Fog Machine Maintenance..... 19

Storage.....	19
6. Technical Specifications	20
Contact Us	21
Warranty & Returns.....	21

Before You Begin

1. Before You Begin

What Is Included

- Vesuvio 4 IP
- Seetronic Powerkon – bare wire
- Omega bracket (x2)
- RF remote
- Quick Reference Guide

Claims

Carefully unpack the product immediately and check the container to make sure all the parts are in the package and are in good condition.



If the box or the contents (the product and included accessories) appear damaged from shipping, or show signs of mishandling, notify the carrier immediately, not Chauvet. Failure to report damage to the carrier immediately may invalidate a claim. In addition, keep the box and contents for inspection.

For other issues, such as missing components or parts, damage not related to shipping, or concealed damage, file a claim with Chauvet within 7 days of delivery.

Text Conventions

Convention	Meaning
1–512	A range of values
50/60	A set of values of which only one can be chosen
Settings	A menu option not to be modified
<ENTER>	A key to be pressed on the product's control panel

Symbols

Symbol	Meaning
	Critical installation, configuration, or operation information. Not following these instructions may make the product not work, cause damage to the product, or cause harm to the operator.
	Important installation or configuration information. The product may not function correctly if this information is not used.
	Useful information.



Any reference to data or power connections in this manual assumes the use of Seetronic IP-rated cables.



The term “DMX” used throughout this manual refers to the USITT DMX512-A digital data transmission protocol.

Connection of the control signal: DMX line

- The product has XLR sockets for DMX input and output.
- Notice: This control circuit is isolated and belongs to the Class 2 data port.

The control circuit has a cumulative leakage current of less than 3.5 mA.

Safety Notes

Read all the following safety notes before working with this product. These notes contain important information about the installation, usage, and maintenance of this product.



This product contains no user-serviceable parts. Any reference to servicing in this User Manual will only apply to properly trained, certified technicians. Do not open the housing or attempt any repairs.



All applicable local codes and regulations apply to proper installation of this product.

- The luminaire is intended for professional use only.
- If the external flexible cable or cord of this luminaire is damaged, it shall be replaced by a special cord or cord exclusively available from the manufacturer or its service agent.
- The light source contained in this luminaire shall only be replaced by the manufacturer or its service agent or a similar qualified person.
- **CAUTION:**
 - This product's housing may be hot when operating. Mount this product in a location with adequate ventilation, at least 20 in (50 cm) from adjacent surfaces.
 - When transferring the product from extreme temperature environments, (e.g., cold truck to warm humid ballroom) condensation may form on the internal electronics of the product. To avoid causing a failure, allow the product to fully acclimate to the surrounding environment before connecting it to power.
 - Flashing light is known to trigger epileptic seizures. User must comply with local laws regarding notification of strobe use.
- **ALWAYS:**
 - When using an IP65-rated product in an outdoor environment, use IP65- (or higher) rated power and data cable.
 - Replace and secure IP-rated protective covers to all power, data, USB, or other ports when not in use.
 - Use a safety cable when mounting this product overhead.
 - Connect this product to a grounded and protected circuit.
 - Drain the tank before transporting the product.
- **DO NOT:**
 - Open this product. It contains no user-serviceable parts.
 - Look at the light source when the product is on.
 - Connect this product to a dimmer or rheostat.
 - Operate this product if the housing, lenses, hoses, fluid tank, or cables appear damaged.
 - Operate this product outdoors or in any location where dust, excessive heat, water, or humidity may affect it (adhere to standards for the published IP rating).
 - Submerge this product (adhere to standards for the published IP rating). Regular outdoor operation is fine.
 - Permanently install outdoors in locations with extreme environmental conditions. This includes, but is not limited to:
 - Exposure to a marine/saline environment (within 3 miles of a saltwater body of water).
 - Locations where normal temperatures exceed the temperature ranges in this manual.
 - Locations that are prone to flooding or being buried in snow.
 - Other areas where the product will be subject to extreme radiation or caustic substances.
 - Use for space-heating purposes.
 - Touch the output nozzle on this product. It is very hot during operation, and it may remain hot for several hours after turning the product off.
 - Add anything to the fluid.
 - Drink the fluid.
 - Allow the fluid to contact skin or eyes.
- **ONLY** use the hanging/mounting bracket to carry this product.
- **ONLY** use Chauvet fluids.
- Depending on the amount of fog/haze generated, all fog/haze machines may set off smoke detectors.
- The IP rating of this product is maintained **ONLY** in the upright position.

Before You Begin

- The maximum ambient temperature is 113 °F (45 °C). Do not operate this product at higher temperatures.
- The minimum startup temperature is -4°F (-20°C). Do not start the product at lower temperatures.
- The minimum ambient temperature is -22°F (-30°C). Do not operate the product at lower temperatures.
- To eliminate unnecessary wear and improve its lifespan, during periods of non-use completely disconnect the product from power via breaker or by unplugging it.
- In the event of a serious operating problem, stop using immediately.



If this Chauvet product requires service, contact Chauvet Technical Support.

FCC Statement of Compliance

This device complies with Part 15 Part B of the FCC rules. Operation is subject to the following two conditions:

1. This device may not cause harmful interference, and
2. This device must accept any interference received, including interference that may cause undesired operation.

This equipment has been tested and found to comply with the limits for a Class B digital device, pursuant to Part 15 of the FCC Rules. These limits are designed to provide reasonable protection against harmful interference in a residential installation. This equipment generates uses and can radiate radio frequency energy and, if not installed and used in accordance with the instructions, may cause harmful interference to radio communications. However, there is no guarantee that interference will not occur in a particular installation. If this equipment does cause harmful interference to radio or television reception, which can be determined by turning the equipment off and on, the user is encouraged to try to correct the interference by one or more of the following measures:

- Reorient or relocate the receiving antenna.
- Increase the separation between the equipment and receiver.
- Connect the equipment into an outlet on a circuit different from that to which the receiver is connected.
- Consult the dealer or an experienced radio/TV technician for help.

Any changes or modifications not expressly approved by the party responsible for compliance could void the user's authority to operate the equipment.

RF Exposure Warning for North America and Australia

Warning! This equipment complies with FCC radiation exposure limits set forth for an uncontrolled environment. This equipment should be installed and operated with a minimum distance of 20 cm between the radiator and the user. This transmitter must not be co-located or operating in conjunction with any other antenna or transmitter.

Expected LED Lifespan

Over time, use and heat will gradually reduce LED brightness. Clustered LEDs produce more heat than single LEDs, contributing to shorter lifespans if always used at full intensity. The average LED lifespan is 40,000 to 50,000 hours. To extend LED lifespan, maintain proper ventilation around the product, and limit the overall intensity.

2. Introduction

Features

- Advanced vertical fogger creates powerful vertical fog bursts, delivering a CO₂-style effect without the need for gas or tanks
- Outdoor-ready design providing reliable operation in wet or damp environments
- High-performance output engineered for extreme throw distances of up to 50 ft (15 m), ensuring maximum visual impact
- Independently controlled RGBA LED zones enable creative color effects and dynamic visuals.
- Durable touring case for easy transport and protection during rental or live event use
- Flexible control options allow for operation via onboard full-color display, wireless RF handheld remote, or DMX integration
- Integrated drainage system simplifies post-use maintenance with quick water evacuation and easy clean-up
- USB-C port allows convenient software and firmware uploads for future updates
- QDF (Quick Dissipating Fluid) ensures optimal performance and clean atmospheric effects

Product Overview

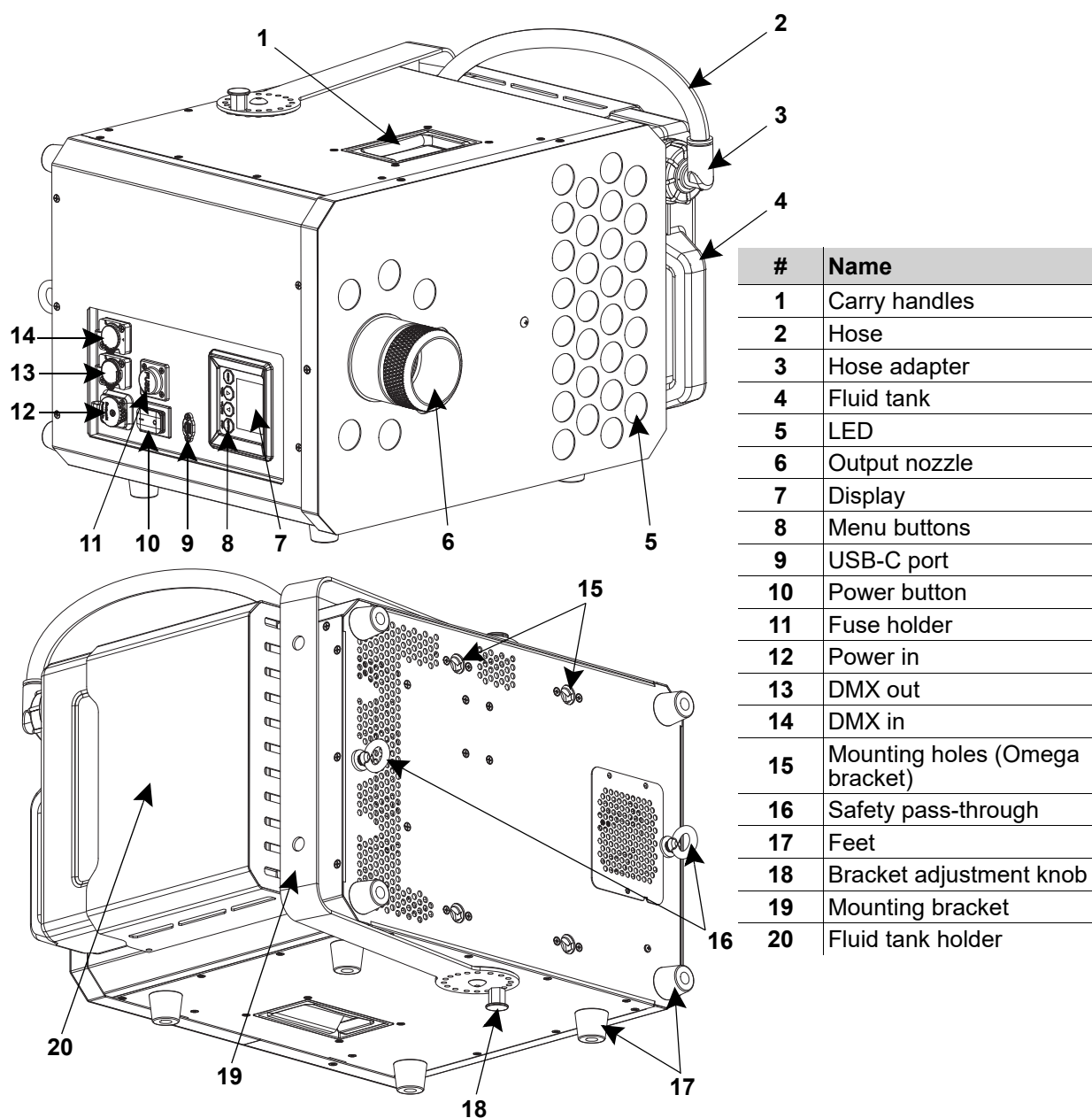

Product Dimensions

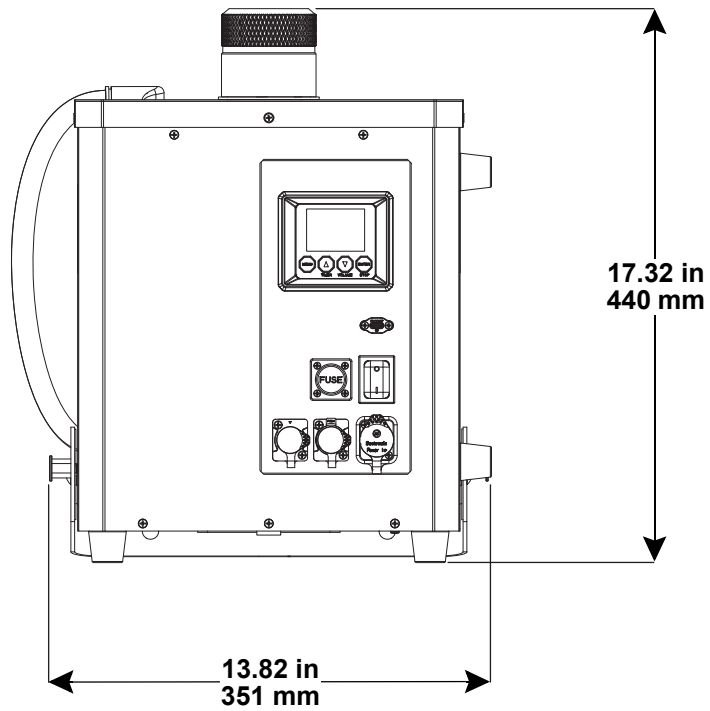
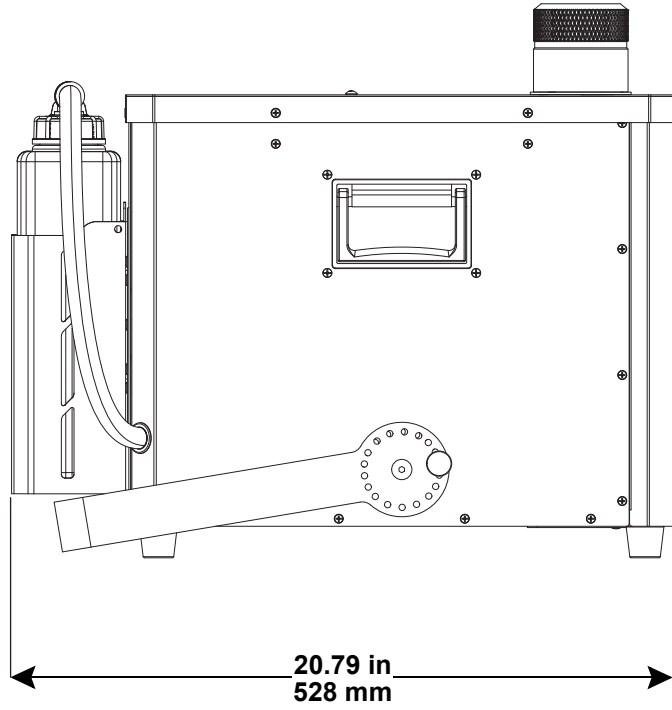

3. Setup

AC Power

The Vesuvio 4 IP has a fixed power supply that works with an input voltage of 208 VAC, 60 Hz.

To determine the product's power requirements (circuit breaker, power outlet, and wiring), use the current value listed on the label affixed to the product's back panel, or refer to the product's specifications chart.

The listed current rating indicates the product's average current draw under normal conditions.



- **Always connect the product to a protected circuit (a circuit breaker or fuse). Ensure the product has an appropriate electrical ground to avoid the risk of electrocution or fire.**
- **To eliminate unnecessary wear and improve its lifespan, during periods of non-use completely disconnect the product from power via breaker or by unplugging it.**



Never connect the product to a rheostat (variable resistor) or dimmer circuit, even if the rheostat or dimmer channel serves only as a 0 to 100% switch.

AC Plug

The Vesuvio 4 IP comes with a power input cable terminated with a Seetronic Powerkon A connector on one end and bare wire on the other end. Use the table below to wire a plug.

Connection	Wire (U.S.)	Wire (Europe)	Screw Color
AC Live	Black	Brown	Yellow or Brass
AC Neutral	White	Blue	Silver
AC Ground	Green/Yellow	Green/Yellow	Green

Resetting the Breaker

This product is equipped with a resettable circuit breaker. If the breaker trips, all sections of this product will lose power.

1. Remove the power cord from main power.
2. Allow unit to cool for 15 minutes.
3. After 15 minutes, user may attempt to reset the breaker by pressing the button with their finger.
4. Plug the product's power cord into the power outlet and continue using as recommended.

DMX Linking

The Vesuvio 4 IP can be linked to a DMX controller using a 5-pin DMX connection. If using other DMX-compatible products with this product, it's possible to control each individually with a single DMX controller.

DMX Personalities

The Vesuvio 4 IP uses a 5-pin DMX data connection for its 11-channel DMX personality.

- Refer to the [Operation](#) chapter to learn how to configure the Vesuvio 4 IP to work in these personalities.
- The [Control Channel Assignments and Values](#) section provides detailed information regarding the DMX personalities.



For information about DMX standards, Master/Slave connectivity, or the DMX cables needed to link this product to a DMX controller, download the DMX Primer from the Chauvet website: www.chauvetprofessional.com.

Remote Device Management

Remote Device Management, or RDM, is a standard for allowing DMX-enabled devices to communicate bi-directionally along existing DMX cabling. Check the DMX controller's User Manual or with the manufacturer as not all DMX controllers have this capability. The Vesuvio 4 IP supports RDM protocol that allows feedback to make changes to menu map options.

USB Software Update

The Vesuvio 4 IP allows for software update through USB using the built-in USB port. To update the software using a USB type C flash drive:

1. Drag the update software onto the main directory of a USB flash drive.
2. With the machine powered off, insert the USB flash drive into the type C port on the Vesuvio 4 IP.
3. Power on the machine. The Vesuvio 4 IP will automatically enter the update program page and display the update progress.
4. Once the update is complete, power off the machine and remove the USB flash drive.



The product's USB port supports up to 32GB capacity and only works with FAT32 file format.

Mounting

Before mounting the product, read and follow the safety recommendations indicated in the [Safety Notes](#).

Orientation

Always mount this product in a safe position, making sure there is adequate room for ventilation, configuration, and maintenance.



The IP rating for this product is maintained **ONLY** in the upright position.

Rigging

Chauvet recommends using the following general guidelines when mounting this product.

- Before deciding on a location for the product, make sure there is easy access to the product for maintenance and programming purposes.
- Make sure that the structure and attachment points can support the weight before hanging the product (see the [Technical Specifications](#) for weight information).
- When mounting the product overhead, always use a safety cable. Mount the product securely to a rigging point, whether an elevated platform or a truss.
- When rigging the product onto a truss, use a mounting clamp of appropriate weight capacity.
- The bracket adjustment knobs allow for directional adjustment when aiming the product to the desired angle. Only loosen or tighten the bracket knobs manually. Using tools could damage the knobs.

Procedure



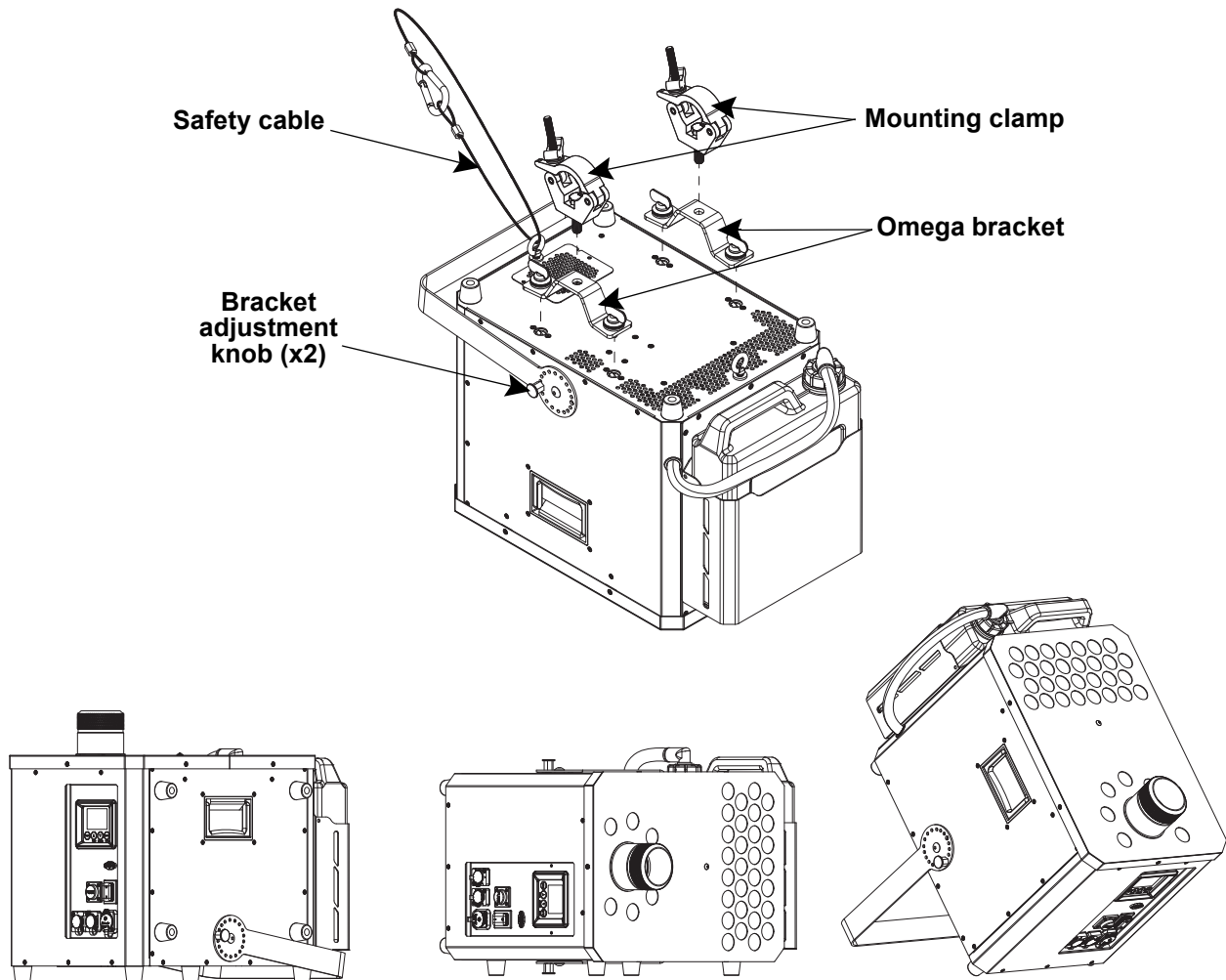

The Vesuvio 4 IP comes with two Omega brackets. The user can directly attach a mounting clamp (sold separately) to this Omega bracket. Make sure the clamp is capable of supporting the weight of this product. For the Chauvet Professional line of mounting clamps, go to <http://www.trusst.com/products>.

Mounting Diagram



4. Operation

Control Panel Description

Button	Name	Function
	<MENU>	Cycles through programming modes
	<UP/ TIMER>	UP navigates upwards through the menu list and increases the numeric value when in a function TIMER starts the timer-controlled operation
	<DOWN/ VOLUME>	DOWN navigates downwards through the menu list and decreases the numeric value when in a function VOLUME triggers the pump to modify the output volume
	<ENTER/ STOP>	ENTER enables the currently displayed menu STOP turns the fog output off

Menu Map

Refer to the Vesuvio 4 IP product page on www.chauvetprofessional.com for the latest menu map.

Main Level	Programming Levels	Description
INTERVAL SET	1-300S	Sets the interval fog output time
DURATION SET	1-10S	Sets the continuous fog output time
LED COLOR	KEY A-D	Sets the color for the LEDs: red, green, blue, yellow, pink, purple, sky blue, white, and random, off
DMX 512	1-502	Selects the DMX starting address
BACKLIGHT TIMER	OFF	Turns off the timer for the LCD display backlight
	10 s	Display turns off after 10 seconds
	30 s	Display turns off after 30 seconds
	2 MIN	Display turns off after 2 minutes
RDM	-----	Unique RDM identification number
REMOTE SETUP	TURN ON	Turns on the remote
	PAIR	Pairs the remote with the product
	CLEAR	Clears all remote functions
	TURN OFF	Turns off the remote

Starting Address

Each product will respond to a unique starting address from the controller. All products with the same starting address will respond in unison. To set the starting address in DMX mode:

1. Go to the **DMX 512**.
2. Select the starting address (**001–502**).

Personality	Highest Address	Products per Universe
11 Ch	502	46

DMX Channel Assignments and Values

11Ch

Channel	Function	Value	Percent/Setting
1	Fog Volume	000 ⇔ 010 011 ⇔ 255	No function 1–100%, thin to heavy
2	Red	000 ⇔ 255	0–100%
3	Green	000 ⇔ 255	0–100%
4	Blue	000 ⇔ 255	0–100%
5	Amber	000 ⇔ 255	0–100%
6	Color macro	000 ⇔ 010 011 ⇔ 255	No function Color indexing
7	Automatic program	000 ⇔ 010 011 ⇔ 255	No function Automatic program, slow to fast
8	Strobe	000 ⇔ 010 011 ⇔ 255	No function LED strobe, slow to fast
9	Dimmer	000 ⇔ 010 011 ⇔ 255	No function LED dimmer, dim to bright
10	Control channel	000 ⇔ 035 036 ⇔ 070 071 ⇔ 105 106 ⇔ 140 141 ⇔ 175 176 ⇔ 210 211 ⇔ 255	No function Heater off No function Heater on No function Reset fixture No function
11	Safety master control	000 ⇔ 127 128 ⇔ 255	Off Safety control activated



- LEDs will automatically turn off after 30 seconds to extend lifespan. This can be reset by moving CH10 to 0 and then back to the desired value.
- The Safety master control only affects the fog channel and has no effect on the LED lights.

Operation

Standalone Configuration

Use standalone configuration to operate the product without a DMX controller. Press menu repeatedly to cycle through each option.

Interval Set

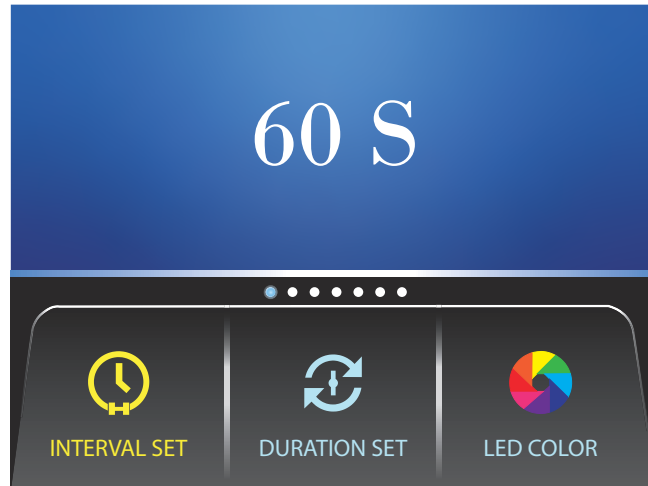

Press **<UP>** or **<DOWN>** to select the interval time between fog output from **(1–300S)**.

Duration Set

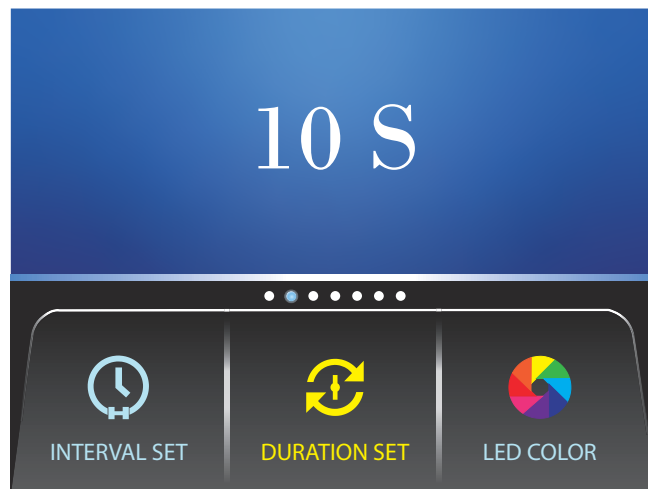

Press **<UP>** or **<DOWN>** to select the continuous fog output time from **(1–60S)**.

LED Color



Press **<ENTER>** to select **KEY A**. Press **<UP>** or **<DOWN>** to select the programmed color options from **OFF** to **RAND** (Random). Press **<MENU>** repeatedly to select from the **KEY A–D** options.

DMX 512

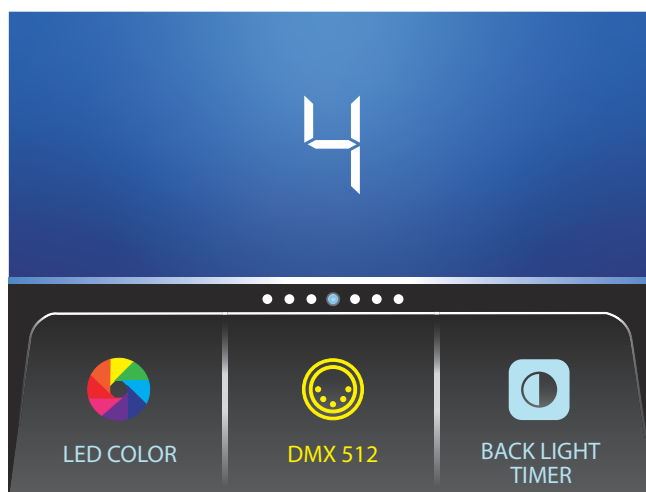

Press **<UP>** or **<DOWN>** to select the starting address from **1–502**.

Operation

Backlight Timer

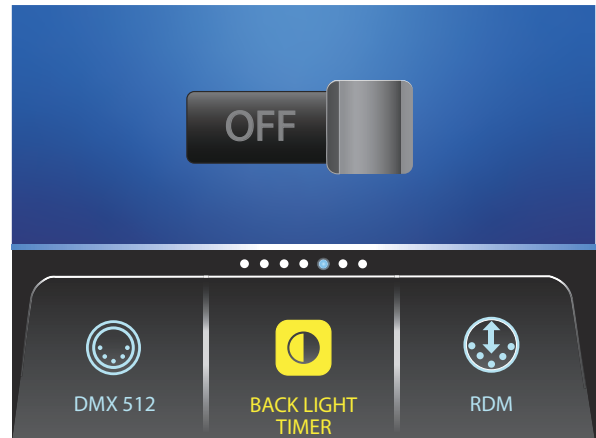
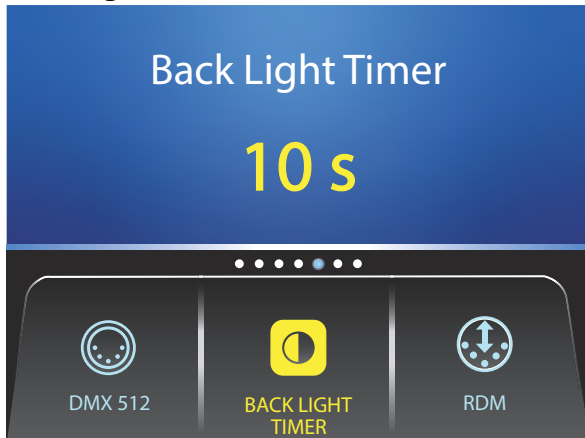

Press <UP> or <DOWN> to set the display backlight timer from **OFF**, **10 s**, **30 s**, or **2 MIN**.

RDM

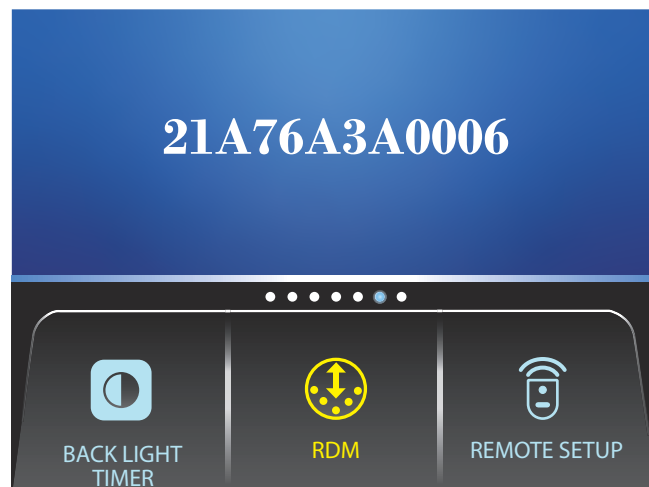

Displays the product's **RDM** identification number.

Remote Setup

Pairing

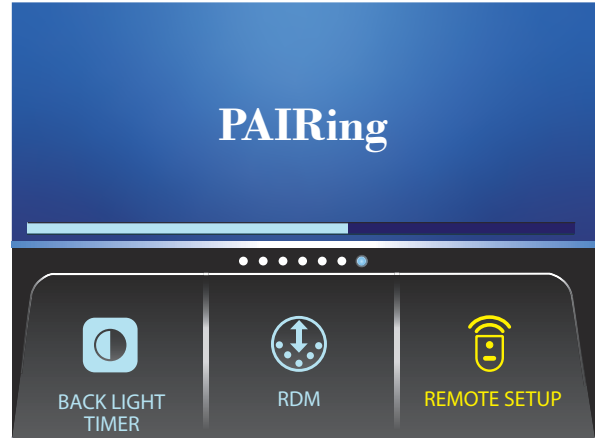
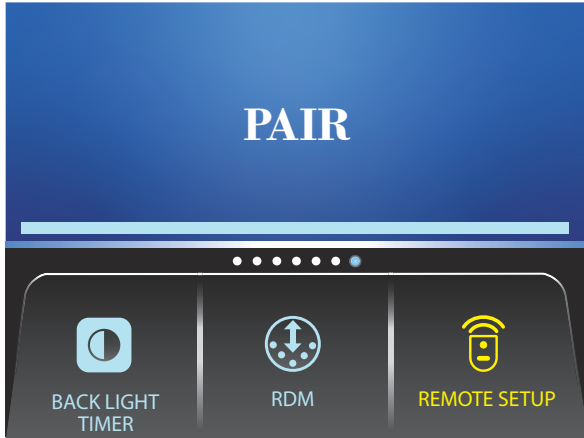

To pair the remote, press **<ENTER>** when **PAIR** is selected. The screen will display **PAIRing**.

Enabling and Disabling Remote Operation

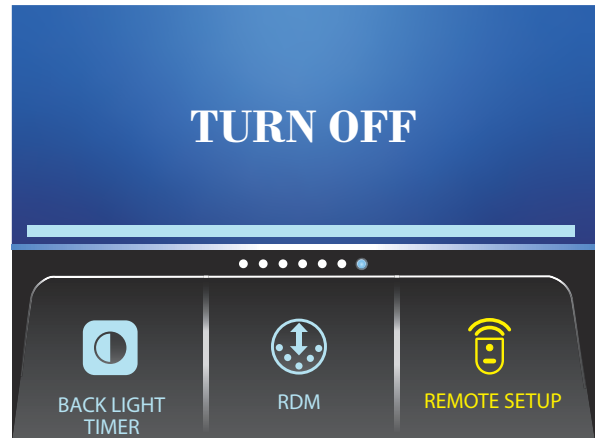
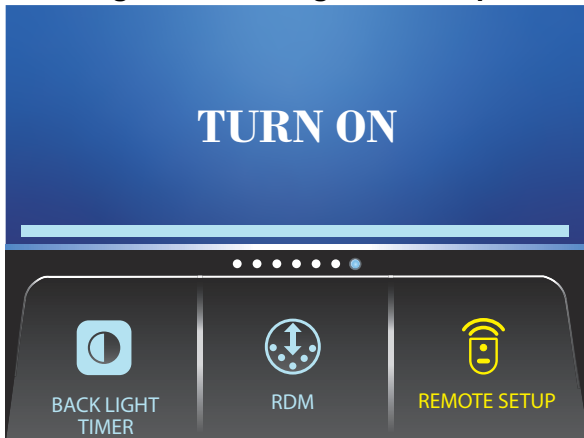

To enable remote operation of the product, press **<UP>** or **<DOWN>** until **Turn On** is displayed and press **<Enter>**.

To disable remote operation of the product, press **<UP>** or **<DOWN>** until **Turn Off** is displayed and press **<Enter>**.

Operation

Clearing Paired Remotes

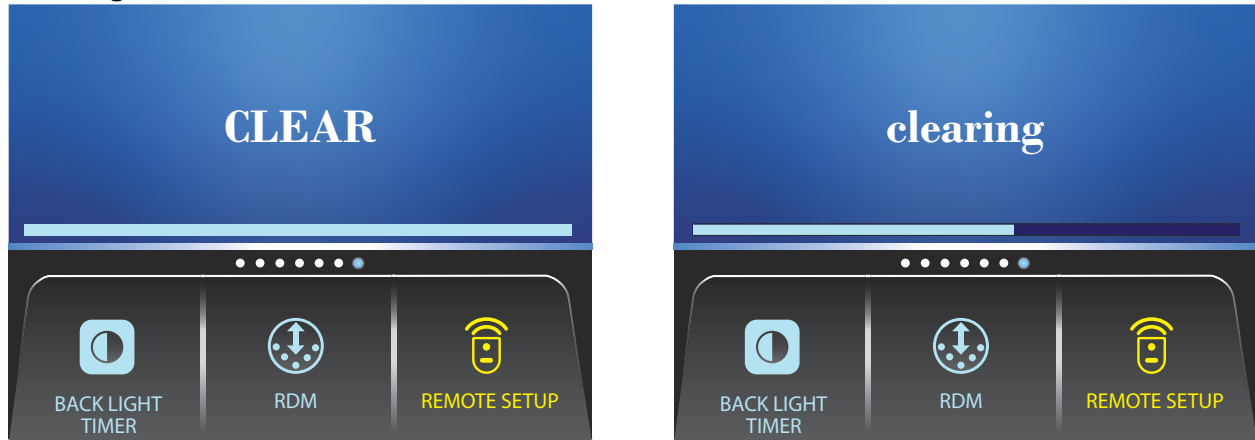

To clear the remote functions, press **<ENTER>** when **CLEAR** is selected. The screen will display **Clearing**.

RF Remote Control Operation

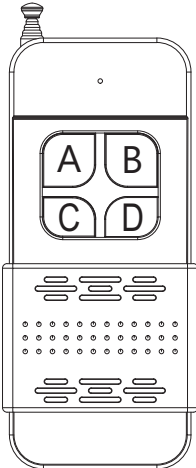
RF	Button	Function
	<A>	Press and hold to fog. LEDs will light up in the color set on Key A in the LED Color submenu.
		Press and hold to fog. LEDs will light up in the color set on Key B in the LED Color submenu.
	<C>	Press and hold to fog. LEDs will light up in the color set on Key C in the LED Color submenu.
	<D>	Press and hold to fog. LEDs will light up in the color set on Key D in the LED Color submenu.

Settings Configuration

The Vesuvio 4 IP allows for user calibration of the product's system settings. To navigate to the calibration menu, press and hold **<Menu>** for 3 seconds:

HEATER TEMPERATURE	211
UPPER TEMPERATURE	210
LOWER TEMPERATURE	38
FAN IDLE SPEED	0
DEFAULT 1	0
DEFAULT 2	OFF
OUTPUT	OFF
VOLUME	1

Press **<Menu>** repeatedly to scroll through the menu options. Press **<UP>** or **<DOWN>** to select the desired value.

Operation

Error Messages

See the table below for error messages and recommended solutions:

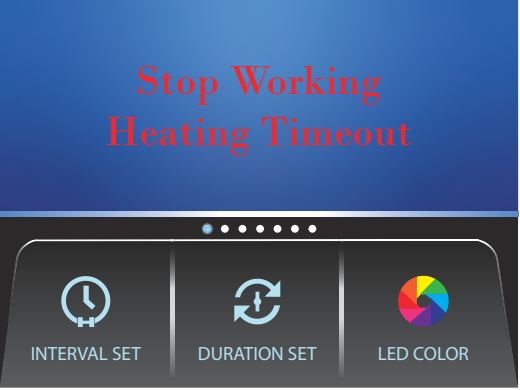
Error Message	Reason and Potential Solution
	<p>The temperature of the heater is over 400°C or the thermocouple of the heated aluminum is open.</p> <p>Shut down the machine and allow it to cool down before restarting.</p>
	<p>The heater is unable to reach operating temperature after 8 minutes of heating.</p> <p>Ensure the machine is in an environment warm enough to function properly.</p>
	<p>The machine is rated for 120 V and is connected to a higher-voltage power source.</p> <p>Ensure the machine is connected to a 120 V power source.</p>

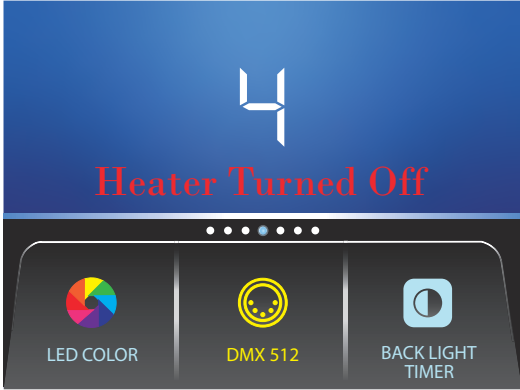
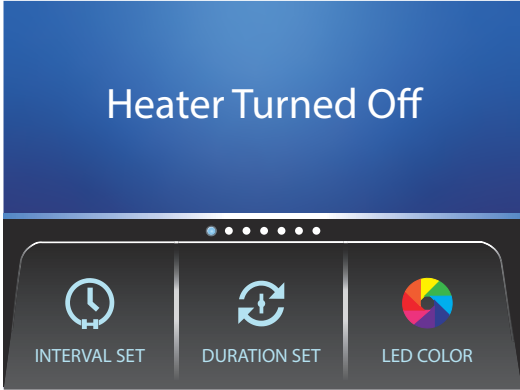
Error Message	Reason and Potential Solution
	<p>The machine is connected to DMX and CH2 is turned off.</p> <p>Ensure that CH2 is set between 151–155.</p>
	<p>The machine is not connected to DMX and the heater is turned off in the product calibration menu.</p> <p>Ensure the heater is turned on in the product calibration menu.</p>

5. Maintenance

Fog Machine Maintenance

Proper maintenance of Chauvet atmospheric products will increase the reliability and lifespan of products. Maintenance should be completed every 30-90 days, depending on how frequently products are used.



- **When performing maintenance, use Chauvet Fog Cleaner Quart (FCQ) for U.S., or cleaning Fluid 250 (CF250) for EU products. Run the fluid through the system to reduce the accumulation of particulate matter in the heating element.**
- **DO NOT allow the atmospheric product to become clogged. Once a product is clogged, the cleaning procedure is unlikely to effectively clear the clog.**

The recommended cleaning procedure is as follows:

1. Unplug the product from power.
2. Remove the hose from the fluid tank/reservoir. Remove the FCQ/CF250 screw cap and place the hose in the Fog Cleaner bottle.
3. Connect the product to power and allow it to warm up (if not already warmed up).
4. Run the FCQ/CF250 through the product in a well-ventilated area for 60-90 seconds of continuous, full output. Some products require multiple cycles to achieve this.



DO NOT allow the product to run dry!

5. Move the hose from the FCQ/CF250 to a small bottle with distilled water (only use distilled water, not tap or any other water or liquid). Run distilled water through the product for at least 30 seconds to clear any remaining cleaning solution from the pump and heater.



- **Turn off the product when not in use or when storing.**
- **DO NOT leave the cleaning solution in the product.**
- **DO NOT operate the product without fluid at any time.**
- **DO NOT leave Chauvet atmospheric fluid in the product tank/reservoir for more than 10 days without use.**



Fog Cleaner Quart (FCQ) and Cleaning Fluid 250 (CF250) were specifically developed by Chauvet to clean Chauvet atmospheric products equipped with heaters. Use FCQ/CF250 regularly, no longer than 90 days between cleanings (30-60 days if the product is used more frequently), to prevent shortening the life of the product.

Storage

Before storing the Chauvet atmospheric product, run FCQ/CF250 through the system as described in the cleaning procedure above and do not refill the tank with atmospheric fluid before storing the product.



Test-run the Chauvet atmospheric products monthly to achieve the best performance.

Chauvet does not guarantee products will withstand storage for long durations, even if the cleaning process is followed. Please use caution and test regularly to ensure the product continues to function properly.

6. Technical Specifications

Dimensions and Weight

Length	Width	Height	Weight
20.79 in (528 mm)	13.82 in (351 mm)	17.32 in (440 mm)	72.2 lb (32.75 kg)

Note: Dimensions in inches are rounded.

Power

Power Supply Type	Range	Voltage Selection
Fixed	208 VAC, 60 Hz	Fixed
Parameter	120 V, 60 Hz	240 V, 50 Hz
Consumption	1541 W	W
Operating Current	12.89 A	A
Breaker	16 A, 250V	16 A, 250V
Power I/O	U.S./Worldwide	UK/Europe
Power Input Connector	Seetronic Powerkon IP65	Seetronic Powerkon IP65
Power Cable plug	Bare wire	Bare wire

Light Source

Type	Color	Quantity	Power	Lifespan
LED	Red Green Blue Amber	37	8 W	50,000 hours

Capacity/Consumption

Tank Capacity	Fluid Consumption	Required Fluid
1.4 gal (5.3 L)	22mL/min	QDF

Operation

Heat-up Time	Maximum Runtime
13 min	45-second bursts

Thermal

Maximum External Temperature	Cooling System
113 °F (45 °C)	Fan-assisted Convection

Control

DMX I/O Connector	Channel Range
5-pin XLR	11

Ordering

Product Name	Item Name	Item Code	UPC Number
Vesuvio 4 IP	VESUVIO4IP	05342761	781462231095



Contact Us

General Information	Technical Support
Chauvet World Headquarters	
Address: 3360 Davie Rd., Suite 509 Davie, FL 33314 Voice: (954) 577-4455 Fax: (954) 929-5560 Toll Free: (800) 762-1084	Voice: (844) 393-7575 Fax: (954) 756-8015 Email: chauvetcs@chauvetlighting.com Website: www.chauvetprofessional.com
Chauvet U.K.	
Address: Pod 1 EVO Park Little Oak Drive, Sherwood Park Nottinghamshire, NG15 0EB UK Voice: +44 (0) 1773 511115 Fax: +44 (0) 1773 511110	Email: UKtech@chauvetlighting.eu Website: www.chauvetprofessional.eu
Chauvet Benelux	
Address: Vaartlaan 9 9800 Deinze Belgium Voice: +32 9 388 93 97	Email: BNLtech@chauvetlighting.eu Website: www.chauvetprofessional.eu
Chauvet France	
Address: 3, Rue Ampère 91380 Chilly-Mazarin France Voice: +33 1 78 85 33 59	Email: FRtech@chauvetlighting.fr Website: www.chauvetprofessional.eu
Chauvet Germany	
Address: Bruno-Bürgel-Str. 11 28759 Bremen Germany Voice: +49 421 62 60 20	Email: DEtech@chauvetlighting.de Website: www.chauvetprofessional.eu
Chauvet Mexico	
Address: Av. de las Partidas 34 - 3B (Entrance by Calle 2) Zona Industrial Lerma Lerma, Edo. de México, CP 52000 Voice: +52 (728) 690-2010	Email: servicio@chauvet.com.mx Website: www.chauvetprofessional.mx

Warranty & Returns

For warranty terms and conditions and return information, please visit our website.

For customers in the United States and Mexico: www.chauvetlighting.com/warranty-registration.

For customers in the United Kingdom, Republic of Ireland, Belgium, the Netherlands, Luxembourg, France, and Germany: www.chauvetlighting.eu/warranty-registration.