

COLORDash Par Bar 4

User Manual



Model ID: COLORDASHPARBAR4

Edition Notes

The COLORdash Par Bar 4 User Manual includes a description, safety precautions, installation, programming, operation, and maintenance instructions for the COLORdash Par Bar 4 as of the release date of this edition.

Trademarks

Chauvet, Chauvet Professional, the Chauvet logo, COLORdash, and COLORdash Par are registered trademarks or trademarks of Chauvet & Sons, LLC (d/b/a Chauvet and Chauvet Lighting) in the United States and other countries. Other company and product names and logos referred to herein may be trademarks of their respective companies.

Copyright Notice

The works of authorship contained in this manual, including, but not limited to, all designs, text, and images are owned by Chauvet.

© Copyright 2026 Chauvet & Sons, LLC. All rights reserved.

Electronically published by Chauvet in the United States of America.

Manual Use

Chauvet authorizes its customers to download and print this manual for professional information purposes only. Chauvet expressly prohibits the usage, copy, storage, distribution, modification, or printing of this manual or its content for any other purpose without written consent from Chauvet.

Document Printing

For best results, print this document in color, on letter size paper (8.5 x 11 in), double-sided. If using A4 paper (210 x 297 mm), configure the printer to scale the content accordingly.

Intended Audience

Any person installing, operating, and/or maintaining this product should completely read through the guide that shipped with the product, as well as this manual, before installing, operating, or maintaining this product.

Disclaimer

Chauvet believes that the information contained in this manual is accurate in all respects. However, Chauvet assumes no responsibility and specifically disclaims any and all liability to any party for any loss, damage, or disruption caused by any errors or omissions in this document, whether such errors or omissions result from negligence, accident, or any other cause. Chauvet reserves the right to revise the content of this document without any obligation to notify any person or company of such revision. However, Chauvet has no obligation to make, and does not commit to make, any such revisions.

Document Revision

Go to www.chauvetprofessional.com for the latest version.

Revision	Date	Description
3	04/2026	Added DMX to RJ45 Pinout diagram.

TABLE OF CONTENTS

- 1. Before You Begin** 1
 - What Is Included 1
 - Claims 1
 - Text Conventions 1
 - Symbols 1
 - Safety Notes..... 2
 - FCC Statement of Compliance 3
 - Expected LED Lifespan..... 3
- 2. Introduction** 4
 - Features 4
 - Product Overview 4
 - Product Dimensions 5
- 3. Setup** 6
 - AC Power 6
 - AC Plug 6
 - Fuse Replacement 6
 - Power Linking..... 6
 - DMX Connection 6
 - DMX Linking..... 7
 - DMX Personalities..... 7
 - Remote Device Management..... 7
 - Master/Slave Connectivity..... 7
 - Firmware Update..... 7
 - Mounting 8
 - Orientation..... 8
 - Rigging 8
 - Procedure..... 8
 - Removable Tripod Mount..... 10
- 4. Operation** 11
 - Control Panel Description 11
 - Control Options 11
 - Programming..... 11
 - Home Screen 11
 - Control Panel Lock..... 11
 - Passcode 11
 - Menu Map 12
 - DMX Configuration 15
 - DMX Personalities..... 15
 - Starting Address..... 15
 - DMX Channel Assignments and Values 15
 - Color Macro Chart..... 15
 - Color Temperature Chart 15
 - Control Chart..... 15
 - 41CH / 36CH / 32CH / 24CH / 14CH / 9CH / 8CH / 6CH..... 16
 - Standalone Configuration..... 17

Fixed Color	17
Color Temperature	17
Manual Color Mixer	17
Auto Show	17
Settings Configuration	17
Master/Slave	17
Dimmer Speed Mode	17
Steady Mode	17
White Balance	17
LED Frequency	18
Back Light	18
Information	18
Factory Reset	18
5. Maintenance.....	19
Product Maintenance	19
6. Technical Specifications	20
Contact Us	21
Warranty & Returns.....	21

Before You Begin

1. Before You Begin

What Is Included

- COLORdash Par Bar 4
- Seetronic Powerkon IP65 power cable
- 4x wide filter
- 4x barndoor
- Removable tripod mount
- Quick Reference Guide

Claims

Carefully unpack the product immediately and check the container to make sure all the parts are in the package and are in good condition.





If the box or the contents (the product and included accessories) appear damaged from shipping, or show signs of mishandling, notify the carrier immediately, not Chauvet. Failure to report damage to the carrier immediately may invalidate a claim. In addition, keep the box and contents for inspection.

For other issues, such as missing components or parts, damage not related to shipping, or concealed damage, file a claim with Chauvet within 7 days of delivery.

Text Conventions

Convention	Meaning
1–512	A range of values
50/60	A set of values of which only one can be chosen
Settings	A menu option not to be modified
<ENTER>	A key to be pressed on the product's control panel

Symbols

Symbol	Meaning
	Critical installation, configuration, or operation information. Not following these instructions may make the product not work, cause damage to the product, or cause harm to the operator.
	Pinch point warning. Not following these instructions may result in damage to, or loss of, tools, digits, or limbs.
	Important installation or configuration information. The product may not function correctly if this information is not used.
	Useful information.

The term “DMX” used throughout this manual refers to the USITT DMX512-A digital data transmission protocol.

Connection of the control signal: DMX line

- The product has XLR sockets for DMX input and output.
- **Notice:** This control circuit is isolated and belongs to the Class 2 data port.

The control circuit has a cumulative leakage current of less than 3.5 mA.

Safety Notes

Read all the following safety notes before working with this product. These notes contain important information about the installation, usage, and maintenance of this product.



This product contains no user-serviceable parts. Any reference to servicing in this User Manual will only apply to properly trained, certified technicians. Do not open the housing or attempt any repairs.



All applicable local codes and regulations apply to proper installation of this product.

- The luminaire is intended for professional use only.
- The luminaire should be positioned so that prolonged staring into the luminaire at a distance closer than 3.28 ft (1 m) is not expected.
- If the external flexible cable or cord of this luminaire is damaged, it shall be replaced by a special cord or cord exclusively available from the manufacturer or its service agent.
- The light source contained in this luminaire shall only be replaced by the manufacturer or its service agent or a similar qualified person.
- **CAUTION:**
 - This product's housing may be hot when operating. Mount this product in a location with adequate ventilation, at least 20 in (50 cm) from adjacent surfaces.
 - When transferring the product from extreme temperature environments, (e.g., cold truck to warm humid ballroom) condensation may form on the internal electronics of the product. To avoid causing a failure, allow the product to fully acclimate to the surrounding environment before connecting it to power.
 - Flashing light is known to trigger epileptic seizures. User must comply with local laws regarding notification of strobe use.
- **ALWAYS:**
 - Disconnect from power before cleaning the product or replacing the fuse.
 - Replace the fuse with the same type and rating.
 - Use a safety cable when mounting this product overhead.
 - Connect this product to a grounded and protected circuit.
- **DO NOT:**
 - Open this product. It contains no user-serviceable parts.
 - Look at the light source when the product is on.
 - Leave any flammable material within 50 cm of this product while operating or connected to power.
 - Connect this product to a dimmer or rheostat.
 - Operate this product if the housing, lenses, or cables appear damaged.
 - Operate this product outdoors or in any location where dust, excessive heat, water, or humidity may affect it (adhere to standards for the published IP rating).
- The maximum ambient temperature is 113 °F (45 °C). Do not operate this product at higher temperatures.
- The minimum startup temperature is -4°F (-20°C). Do not start the product at lower temperatures.
- The minimum ambient temperature is -22°F (-30°C). Do not operate the product at lower temperatures.
- To eliminate unnecessary wear and improve its lifespan, during periods of non-use completely disconnect the product from power via breaker or by unplugging it.
- In the event of a serious operating problem, stop using immediately.



If this Chauvet product requires service, contact Chauvet Technical Support.

Before You Begin

FCC Statement of Compliance

This device complies with Part 15 Part B of the FCC rules. Operation is subject to the following two conditions:

1. This device may not cause harmful interference, and
2. This device must accept any interference received, including interference that may cause undesired operation.

This equipment has been tested and found to comply with the limits for a Class B digital device, pursuant to Part 15 of the FCC Rules. These limits are designed to provide reasonable protection against harmful interference in a residential installation. This equipment generates uses and can radiate radio frequency energy and, if not installed and used in accordance with the instructions, may cause harmful interference to radio communications. However, there is no guarantee that interference will not occur in a particular installation. If this equipment does cause harmful interference to radio or television reception, which can be determined by turning the equipment off and on, the user is encouraged to try to correct the interference by one or more of the following measures:

- Reorient or relocate the receiving antenna.
- Increase the separation between the equipment and receiver.
- Connect the equipment into an outlet on a circuit different from that to which the receiver is connected.
- Consult the dealer or an experienced radio/TV technician for help.

Any changes or modifications not expressly approved by the party responsible for compliance could void the user's authority to operate the equipment.

Expected LED Lifespan

Over time, use and heat will gradually reduce LED brightness. Clustered LEDs produce more heat than single LEDs, contributing to shorter lifespans if always used at full intensity. The average LED lifespan is 40,000 to 50,000 hours. To extend LED lifespan, maintain proper ventilation around the product, and limit the overall intensity.

2. Introduction

Features

- Complete, 4-head wash lighting solution with high-power RGBAW-UV LED Arrays
- Multiple, convenient mounting options for maximum versatility
- Independently focusable heads allow for customizable stage coverage
- Included barndoors for each head to cut light out of unwanted areas
- Easily connect to DMX control using standard CAT6 Ethernet cable
- Adjustable PWM (Pulse Width Modulation) to avoid flickering on camera
- RDM (Remote Device Management) for added flexibility
- Selectable, smooth dimming curves for eliminate flicker and choppiness in fades
- Easy to read OLED display with password protection and touchscreen interface
- Advanced optics provide exceptional color mixing and high efficiency

Product Overview

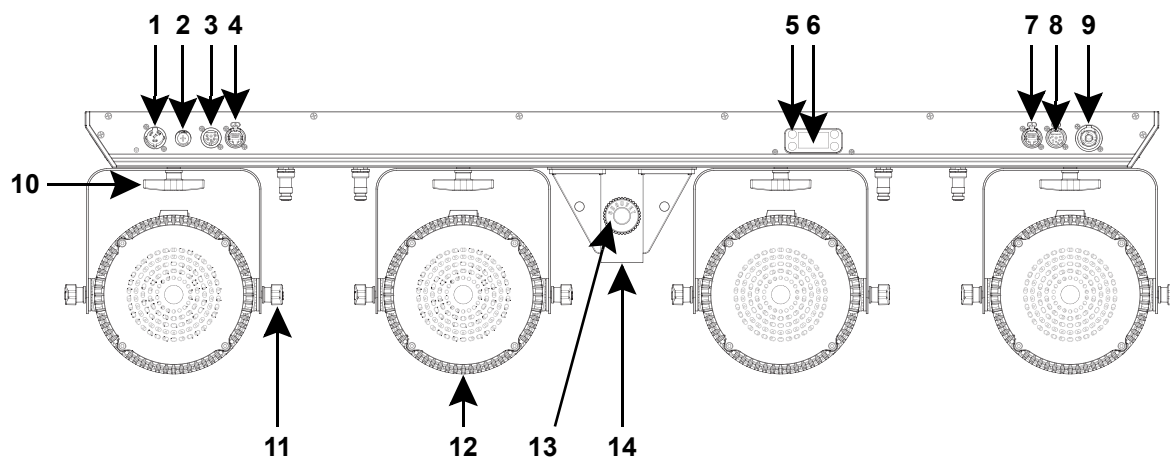

#	Name	#	Name
1	Power in	8	5-pin DMX out
2	Fuse holder	9	Power out
3	5-pin DMX in	10	Par pan knob (x4)
4	Ethernet DMX in	11	Par tilt knob (x8)
5	Menu buttons	12	Par (x4)
6	Menu display	13	Tripod mount knob
7	Ethernet DMX out	14	Tripod insertion point

Product Dimensions

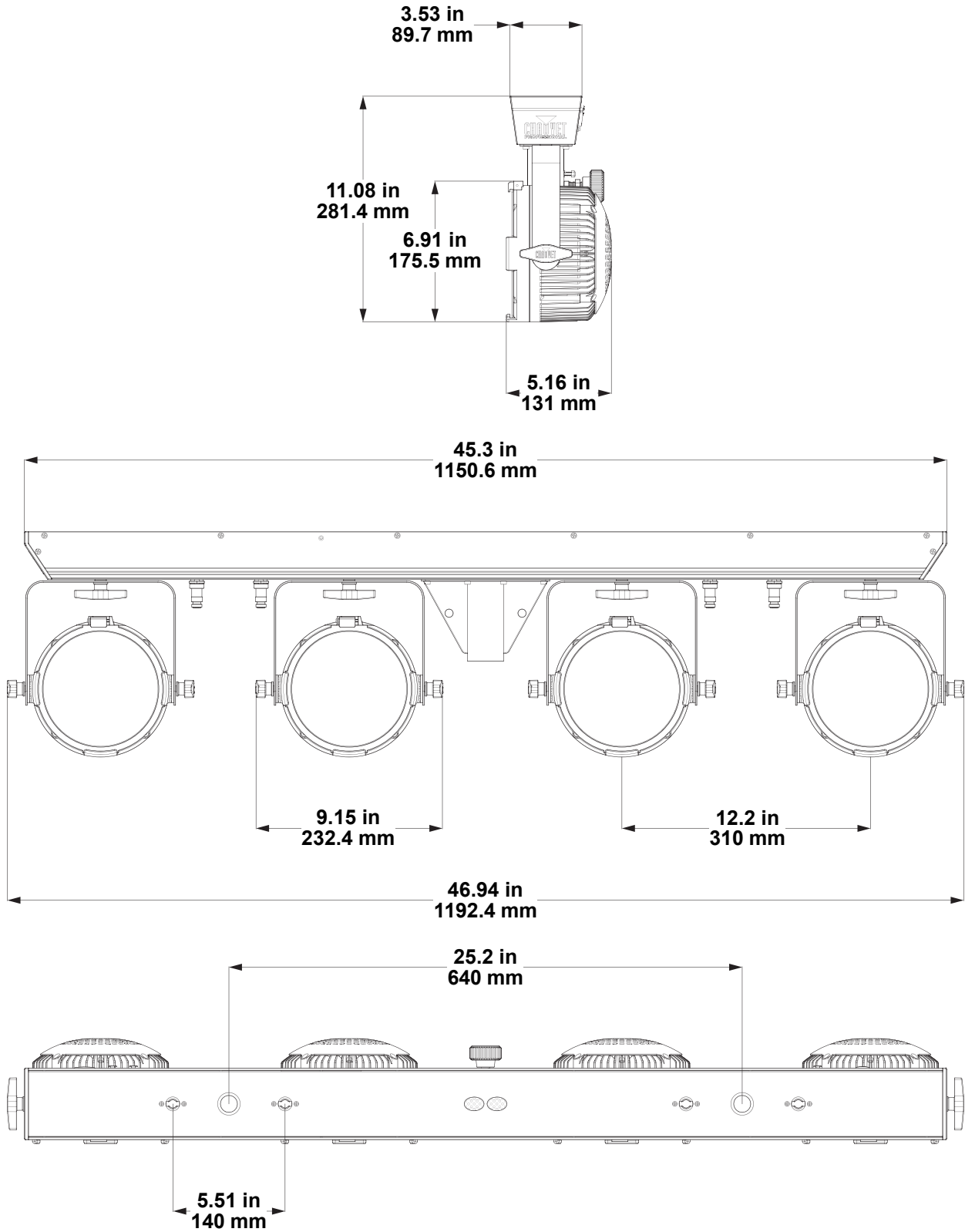

3. Setup

AC Power

The COLORdash Par Bar 4 has an auto-ranging power supply and it can work with an input voltage range of 100 to 240 VAC, 50/60 Hz.

To determine the product's power requirements (circuit breaker, power outlet, and wiring), use the current value listed on the label affixed to the product's back panel, or refer to the product's specifications chart. The listed current rating indicates the product's average current draw under normal conditions.



- **Always connect the product to a protected circuit (a circuit breaker or fuse). Ensure the product has an appropriate electrical ground to avoid the risk of electrocution or fire.**
- **To eliminate unnecessary wear and improve its lifespan, during periods of non-use completely disconnect the product from power via breaker or by unplugging it.**



Never connect the product to a rheostat (variable resistor) or dimmer circuit, even if the rheostat or dimmer channel serves only as a 0 to 100% switch.

AC Plug

The COLORdash Par Bar 4 comes with a power input cable terminated with a Seetronic Powerkon A connector on one end and an Edison plug on the other end (U.S. market). If the power cable which came with the product has no plug, or if it is necessary to change the plug, use the table below to wire a plug.

Connection	Wire (U.S.)	Wire (Europe)	Screw Color
AC Live	Black	Brown	Yellow or Brass
AC Neutral	White	Blue	Silver
AC Ground	Green/Yellow	Green/Yellow	Green

Fuse Replacement

1. Disconnect this product from the power outlet.
2. Using a flat-head screwdriver, unscrew the fuse holder cap from the housing.
3. Remove the blown fuse and replace with another fuse of the same type and rating (T10AL).
4. Screw the fuse holder cap back in place and reconnect power.

Power Linking

It is possible to power link COLORdash Par Bar 4 products. See the table below for the current draw at each voltage and frequency:

	100 V, 60 Hz	120 V, 60 Hz	208 V, 60 Hz	230 V, 50 Hz	240 V, 50 Hz
Current Draw	5.55 A	4.63 A	2.63 A	2.41 A	2.33 A

Never exceed 12 A on a single circuit. Power-linking cables can be purchased separately.

DMX Connection

It is possible to establish DMX control using standard CAT6 Ethernet cable. The ESTA color code for termination of DMX512 is as follows:

RJ45 Pin	Function	Wire Color	5-Pin XLR
1	Ground	White / brown	1
2	Data -1	Orange	2
3	Data +1	White / Orange	3
4	Ground	Brown	1
5	Data -2	Green	4
6	Data +2	White / green	5

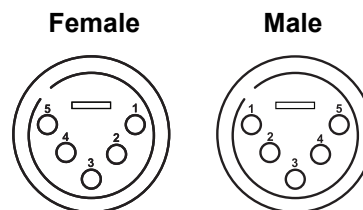

*Connector positions 7 and 8 are unassigned

DMX Linking

The COLORdash Par Bar 4 can be linked to a DMX controller using a 5-pin or an ethernet DMX connection. If using other DMX-compatible products with this product, it's possible to control each individually with a single DMX controller.

DMX Personalities

The COLORdash Par Bar 4 uses a 5-pin or an ethernet DMX data connection for its 8 DMX personalities, ranging from **6CH** to **41CH**.

- Refer to the [Operation](#) chapter to learn how to configure the COLORdash Par Bar 4 to work in these personalities.
- The [DMX Channel Assignments and Values](#) section provides detailed information regarding the DMX personalities.



For information about DMX standards, Master/Slave connectivity, or the DMX cables needed to link this product to a DMX controller, download the DMX Primer from the Chauvet website: www.chauvetprofessional.com.

Remote Device Management

Remote Device Management, or RDM, is a standard for allowing DMX-enabled devices to communicate bi-directionally along existing DMX cabling. Check the DMX controller's User Manual or with the manufacturer as not all DMX controllers have this capability. The COLORdash Par Bar 4 supports RDM protocol that allows feedback to make changes to menu map options.

Master/Slave Connectivity

The Master/Slave mode allows an COLORdash Par Bar 4 (the master) to control one or more COLORdash Par Bar 4 products (the slaves) without a DMX controller. One COLORdash Par Bar 4 becomes the master when running an auto program or in Static mode.

Each slave's control panel must be configured to operate in Slave mode. During Master/Slave operation, the slaves will operate in unison with the master.



DO NOT connect a DMX controller to products operating in Master/Slave mode. The DMX controller signals may interfere with the signals from the master.



- The [Operation](#) section of this manual provides detailed instructions on how to configure the master and slaves.
- For more information about DMX standards or the DMX cables needed to link this product to a DMX controller, download the DMX primer from the Chauvet website: www.chauvetprofessional.com.

Firmware Update

To update the firmware of the COLORdash Par Bar 4 with the UPLOAD 10 USB to DMX adapter cable from Chauvet Professional and a USB Type A flash drive, do the following:

1. Download the latest firmware update from <https://github.com/Chauvet-pro>.
2. Save the firmware file in the root directory on an empty flash drive under 16 GB.
3. Plug the flash drive into the USB side of the UPLOAD 10.
4. Power on the product, and plug the DMX side of the UPLOAD 10 into the 5-pin DMX in port of the COLORdash Par Bar 4.
5. Go to the **System Update** main level.
6. Read the instructions, navigate down, and select the **YES** option.
7. When the update is complete, it is safe to remove the UPLOAD 10.



Turning off the power, removing the USB, or removing the UPLOAD 10 during the update will cause partial or total firmware failure in the COLORdash Par Bar 4. If this occurs, please contact Chauvet.

Mounting

Before mounting the product, read and follow the safety recommendations indicated in the [Safety Notes](#).

Orientation

Always mount this product in a safe position, making sure there is adequate room for ventilation, configuration, and maintenance.

Rigging

Chauvet recommends using the following general guidelines when mounting this product.

- Before deciding on a location for the product, make sure there is easy access to the product for maintenance and programming purposes.
- Make sure that the structure and attachment points can support the weight before hanging the product (see the [Technical Specifications](#) for weight information).
- When mounting the product overhead, always use a safety cable. Mount the product securely to a rigging point, whether an elevated platform or a truss.
- When rigging the product onto a truss, use a mounting clamp of appropriate weight capacity.
- When power linking multiple products, mount the products close enough for power-linking cables to reach.
- The pan and tilt knobs allow for directional adjustment when aiming the pars to the desired angle. Only loosen or tighten the knobs manually. Using tools could damage the knobs.

Procedure

The COLORdash Par Bar 4 comes with 2 Omega brackets. The user can directly attach mounting clamps (sold separately) to these Omega brackets. It is also possible to mount this product with 3/4 in. NPT threaded pipes. Make sure the mounting hardware is capable of supporting the weight of this product. For the Chauvet Professional line of mounting clamps, go to <http://www.trusst.com/products>.

Overhead Mounting Diagram

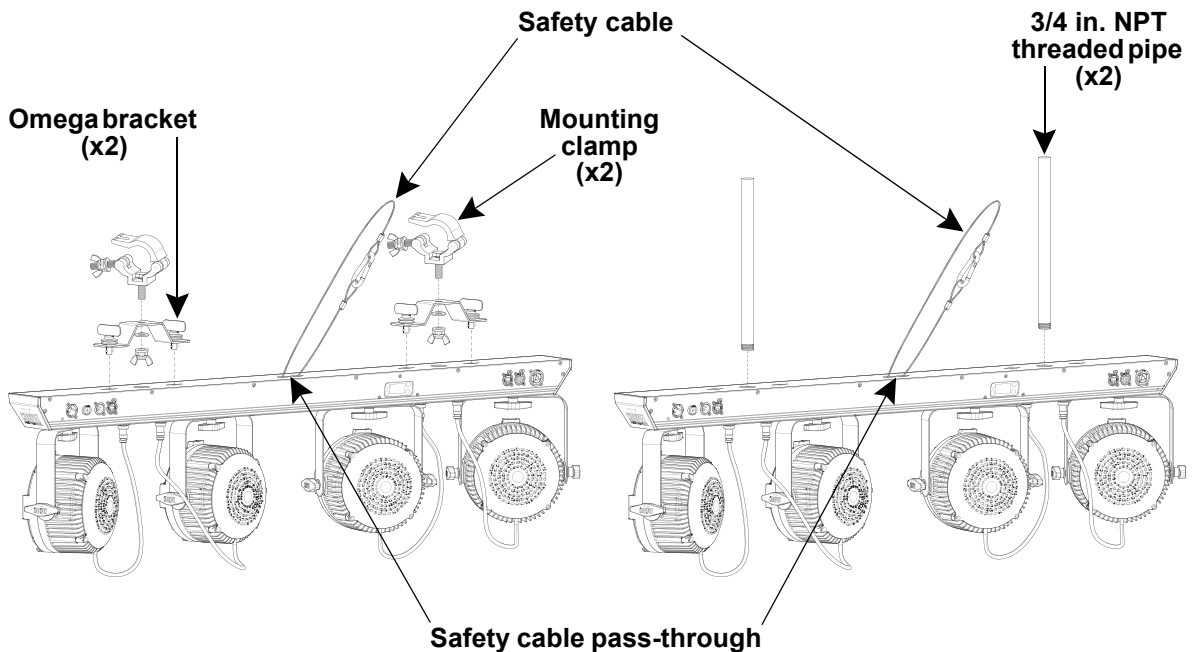

Setup

Tripod Mounting Diagram

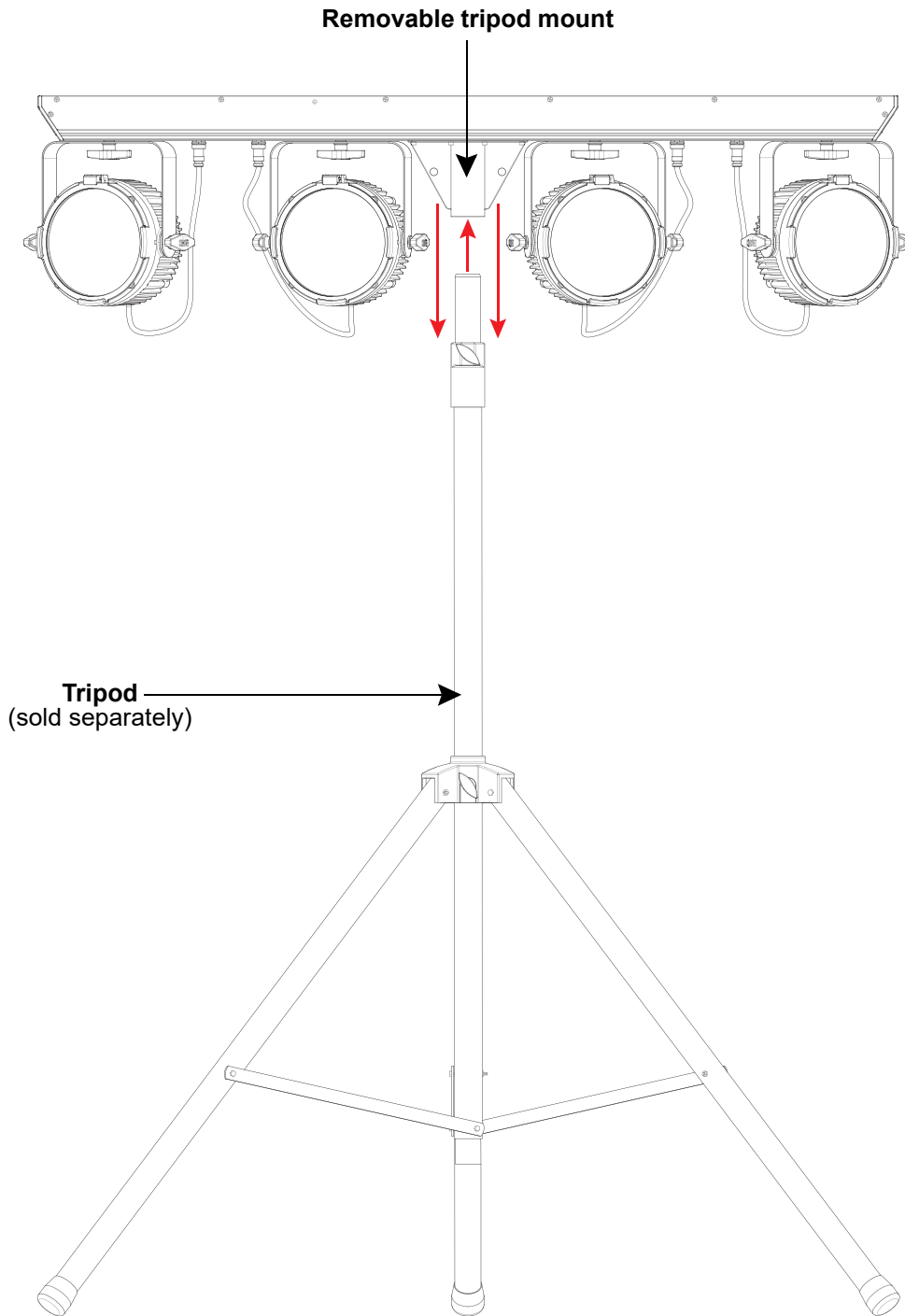



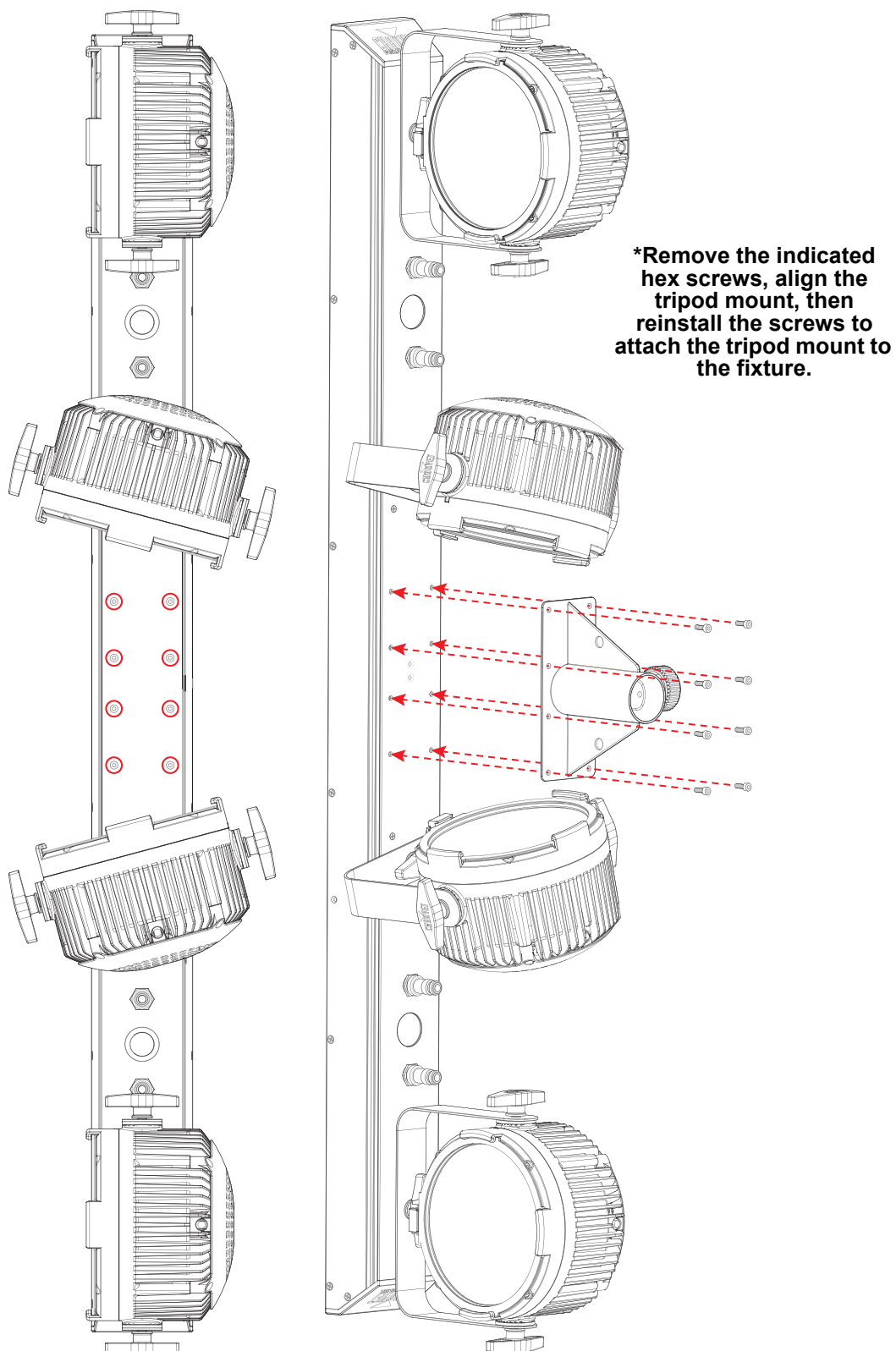

Removable Tripod Mount

It is possible to remove and re-install the included tripod mount with the 8 included hex screws.



4. Operation

Control Panel Description

Button	Name	Function
	<Menu>	Exits the current menu or function
	<Enter>	Enables the currently displayed menu or sets a selected value into a function
	<Up>	Navigates upwards through the menu or increases the numeric value of a function
	<Down>	Navigates downwards through the menu or decreases the numeric value of a function

Control Options

Set the COLORdash Par Bar 4 starting address in the **001-472** DMX range. This enables control of up to 12 products in the 41-channel **41CH** personality.

Programming

Refer to the menu map to understand the menu options. The menu map shows the main menu and a variable number of programming levels for each option.

- To access the main menu, press **<Menu>**.
- To access the main menu from the home screen, press **<Menu>**.
- To navigate to the desired option in the main menu, press **<Menu>** repeatedly until the option is indicated, or use **<Up>** or **<Down>** to navigate directly.
- Press **<Enter>** to select the indicated option.
- Use **<Up>** or **<Down>** to navigate within a programming level until the desired option is indicated.
- To return to the main menu, press **<Menu>** repeatedly until it shows on the display.
- Press and hold **<Menu>** to return to the home screen.

Home Screen

The COLORdash Par Bar 4 has a home screen that shows the current control mode, personality, starting address, and par temperatures in °C. To see the home screen, press and hold **<Menu>** until it shows on the display. From the home screen, press **<Menu>** to reach the main menu.

Control Panel Lock

The setting locks or unlocks the control panel.

1. Go to the **Key Lock** main level.
2. Select **On** (locks control panel) or **Off** (control panel stays unlocked).



When the control panel lock is activated, the product will prompt for the passcode in order to access the menu. Enter the passcode as described below.

Passcode

When prompted, enter the following passcode: **<Up>**, **<Down>**, **<Up>**, **<Down>**, **<Enter>**.

It is not possible to change this passcode.

Menu Map

Refer to the COLORdash Par Bar 4 product page on www.chauvetprofessional.com for the latest menu map.

Main Level	Programming Levels		Description
DMX Address	001–507		Selects DMX address (highest channel restricted to personality chosen)
DMX Channel	6CH		6-channel: RGBAWUV
	8CH		8-channel: dimmer, RGBAWUV, strobe
	9CH		9-channel: 16-bit dimmer, RGBAWUV, strobe
	14CH		14-channel: 16-bit dimmer, RGBAWUV, strobe, color macro, color temperature, auto program and speed, control
	24CH		24-channel: 4-par RGBAWUV
	32CH		32-channel: 4-par dimmer, 4-par RGBAWUV, 4-par strobe
	36CH		36-channel: 4-par 16-bit dimmer, 4-par RGBAWUV, 4-par strobe
Static	Fixed Color	R	Red
		G	Green
		B	Blue
		A	Amber
		W	White
		UV	Ultraviolet (UV)
		RG	Red and green
		RB	Red and blue
		RA	Red and amber
		RW	Red and white
		RUV	Red and UV
		GB	Green and blue
		GA	Green and amber
		GW	Green and white
		GUV	Green and UV
		BA	Blue and amber
		BW	Blue and white
		BUV	Blue and UV
		AW	Amber and white
		AUV	Amber and UV
		WUV	White and UV
		RGB	Red, green, and blue
		RGA	Red, green, and amber
		RGW	Red, green, and white
		RGUV	Red, green, and UV
		RBA	Red, blue, and amber
		RBW	Red, blue, and white
		RBUV	Red, Blue, and UV
		RAW	Red, amber, and white
		RAUV	Red, amber, and UV
		RWUV	Red, white, and UV
		GBA	Green, blue, and amber
GBW	Green, blue, and white		
		Dimmer 000–255	

Main Level	Programming Levels		Description			
Static (cont.)	Fixed Color (cont.)	GBUV	Green, blue, and UV			
		GAW	Green, amber, and white			
		GAUV	Green, amber, and UV			
		GWUV	Green, white, and UV			
		BAW	Blue, amber, and white			
		BAUV	Blue, amber, and UV			
		BWUV	Blue, white, and UV			
		AWUV	Amber, white, and UV			
		RGBA	Red, green, blue, and amber			
		RGBW	Red, green, blue, and white			
		RGBUV	Red, green, blue, and UV			
		RGAW	Red, green, amber, and white			
		RGAUV	Red, green, amber, and UV			
		RGWUV	Red, green, white, and UV			
		RBAW	Red, blue, amber, and white			
		RBAUV	Red, blue, amber, and UV			
		RBWUV	Red, blue, white, and UV			
		RAWUV	Red, amber, white, and UV			
		GBAW	Green, blue, amber, and white			
		GBAUV	Green, blue, amber, and UV			
		GBWUV	Green, blue, white, and UV			
		GAWUV	Green, amber, white, and UV			
		BAWUV	Blue, amber, white, and UV			
		RGBAW	Red, green, blue, amber, and white			
		RGBAUV	Red, green, blue, amber, and UV			
		RGBWUV	Red, green, blue, white, and UV			
		RGAWUV	Red, green, amber, white, and UV			
		RBAWUV	Red, blue, amber, white, and UV			
	GBAWUV	Green, blue, amber, white, and UV				
	RGBAWUV	Red, green, blue, amber, white, and UV				
	Color Temperature	Warm White 1	Dimmer 000–255	Preset white color temperatures		
		Warm White 2				
		Warm White 3				
Neutral White 1						
Neutral White 2						
Neutral White 3						
Daylight 1						
Daylight 2						
Daylight 3						
Daylight 4						
Manual Color Mixer		Red			000–255	Combine red, green, blue, amber, white, and UV to make a custom color temperature
		Green				
		Blue				
	Amber					
	White					
	UV					
Auto Show	Auto 1–5	001–100	Selects automatic programs and program speed			
Master/ Slave	Master		DMX mode (Master)			
	Slave		Slave mode			

Main Level	Programming Levels		Description	
Dimmer Mode	Off		Linear dimmer	
	Dimmer 1–3		Dimmer speed, fast (1) to slow (3)	
Steady Mode	On		Uses a lower maximum output intensity at a constant rate to regulate temperature	
	Off		Adjusts maximum output intensity over time to regulate temperature	
White Balance	Off		Uses factory default white setting	
	Manual	Red	125–255	Sets red LED maximum value
		Green		Sets green LED maximum value
		Blue		Sets blue LED maximum value
		Amber		Sets amber LED maximum value
		White		Sets white LED maximum value
UV	Sets UV LED maximum value			
LED Frequency	600Hz		Sets the PWM frequency	
	1200Hz			
	2000Hz			
	4000Hz			
	6000Hz			
	25KHz			
Back Light	10S		Turns off display backlight after 10 seconds of inactivity	
	30S		Turns off display backlight after 30 seconds of inactivity	
	2Min		Turns off display backlight after 2 minutes of inactivity	
	Always On		Display backlight always on	
Key Lock	On		Locks display (password is <UP>, <DOWN>, <UP>, <DOWN>, <ENTER>)	
	Off			
Information	Fixture Hours	<_ _ _ _ H>	Shows total hours the product has been powered on	
	Version	<V1.00>	Shows current firmware version	
	UID	<_ _ _ _ _>	Shows product UID	
Factory Reset	NO		Resets the product to factory default settings	
	YES			
System Update	NO		Update firmware with the UPLOAD 10 from Chauvet Professional	
	YES			

Operation

DMX Configuration

Use control configurations to operate the product with a DMX controller.

DMX Personalities

To set the DMX personality:

1. Go to the **DMX Channel** main level.
2. Select the desired personality, from **6CH, 8CH, 9CH, 14CH, 24CH, 32CH, 36CH, or 41CH**.



- See the [Starting Address](#) section for the highest selectable starting address for each personality.
- Make sure that the starting addresses on the various products do not overlap due to the new personality setting.

Starting Address

Each product will respond to a unique starting address from the controller. All products with the same starting address will respond in unison. To set the starting address in DMX mode:

1. Go to the **DMX Address** main level.
2. Select the starting address (**001–507**).

Personality	Highest Address	Products per Universe	Personality	Highest Address	Products per Universe
6CH	507	85	24CH	489	21
8CH	505	64	32CH	481	16
9CH	504	56	36CH	477	14
14CH	499	36	41CH	472	12

DMX Channel Assignments and Values

Color Macro Chart

Value	Percent/Setting	Value	Percent/Setting	Value	Percent/Setting
000 ⇔ 010	No function	071 ⇔ 090	Cyan to blue	151 ⇔ 170	RGB full to blue
011 ⇔ 030	Red to yellow	091 ⇔ 110	Cyan to magenta	171 ⇔ 200	RGBA full
031 ⇔ 050	Yellow to green	111 ⇔ 130	Magenta to red	201 ⇔ 255	Amber to RGB full
051 ⇔ 070	Green to cyan	131 ⇔ 150	Red to RGB full		

Color Temperature Chart

Value	Percent/Setting	Value	Percent/Setting	Value	Percent/Setting
000 ⇔ 005	No function	076 ⇔ 100	Neutral white 1	176 ⇔ 200	Daylight 2
006 ⇔ 025	Warm white 1	101 ⇔ 125	Neutral white 2	201 ⇔ 225	Daylight 3
026 ⇔ 050	Warm white 2	126 ⇔ 150	Neutral white 3	226 ⇔ 250	Daylight 4
051 ⇔ 075	Warm white 3	151 ⇔ 175	Daylight 1	251 ⇔ 255	No function

Control Chart

Value	Percent/Setting	Value	Percent/Setting	Value	Percent/Setting
000 ⇔ 005	No function	046 ⇔ 050	PWM 6000 Hz	091 ⇔ 095	No function
006 ⇔ 010	Dimmer mode off	051 ⇔ 055	PWM 25 KHz	096 ⇔ 140	Reserved for future use
011 ⇔ 015	Dimmer mode 1 (fast)	056 ⇔ 060	Display lock on	141 ⇔ 145	Steady mode on
016 ⇔ 020	Dimmer mode 2	061 ⇔ 065	Display lock off	146 ⇔ 150	Steady mode off
021 ⇔ 025	Dimmer mode 3 (slow)	066 ⇔ 070	10 sec backlight timer	151 ⇔ 155	Manual white balance
026 ⇔ 030	PWM frequency 600 Hz	071 ⇔ 075	30 sec backlight timer	156 ⇔ 160	White balance off
031 ⇔ 035	PWM 1200 Hz	076 ⇔ 080	2 min backlight timer	161 ⇔ 249	Reserved for future use
036 ⇔ 040	PWM 2000 Hz	081 ⇔ 085	Backlight always on	250 ⇔ 255	No function
041 ⇔ 045	PWM 4000 Hz	086 ⇔ 090	Reserved for future use		

41CH / 36CH / 32CH / 24CH / 14CH / 9CH / 8CH / 6CH

6	8	9	14	24	32	36	41	Function	Value	Percent/Setting
-	1	1	1	-	1	1	1	Dimmer (1)	000 ⇄ 255	0–100%
-	-	2	2	-	-	2	2	Fine dimmer (1)	000 ⇄ 255	0–100%
1	2	3	3	1	2	3	3	Red (1)	000 ⇄ 255	0–100%
2	3	4	4	2	3	4	4	Green (1)	000 ⇄ 255	0–100%
3	4	5	5	3	4	5	5	Blue (1)	000 ⇄ 255	0–100%
4	5	6	6	4	5	6	6	Amber (1)	000 ⇄ 255	0–100%
5	6	7	7	5	6	7	7	White (1)	000 ⇄ 255	0–100%
6	7	8	8	6	7	8	8	UV (1)	000 ⇄ 255	0–100%
-	8	9	9	-	8	9	9	Strobe (1)	000 ⇄ 010 011 ⇄ 255	No function Strobe, slow to fast
-	-	-	-	-	9	10	10	Dimmer 2	000 ⇄ 255	0–100%
-	-	-	-	-	-	11	11	Fine dimmer 2	000 ⇄ 255	0–100%
-	-	-	-	7	10	12	12	Red 2	000 ⇄ 255	0–100%
-	-	-	-	8	11	13	13	Green 2	000 ⇄ 255	0–100%
-	-	-	-	9	12	14	14	Blue 2	000 ⇄ 255	0–100%
-	-	-	-	10	13	15	15	Amber 2	000 ⇄ 255	0–100%
-	-	-	-	11	14	16	16	White 2	000 ⇄ 255	0–100%
-	-	-	-	12	15	17	17	UV 2	000 ⇄ 255	0–100%
-	-	-	-	-	16	18	18	Strobe 2	000 ⇄ 010 011 ⇄ 255	No function Strobe, slow to fast
-	-	-	-	-	17	19	19	Dimmer 3	000 ⇄ 255	0–100%
-	-	-	-	-	-	20	20	Fine dimmer 3	000 ⇄ 255	0–100%
-	-	-	-	13	18	21	21	Red 3	000 ⇄ 255	0–100%
-	-	-	-	14	19	22	22	Green 3	000 ⇄ 255	0–100%
-	-	-	-	15	20	23	23	Blue 3	000 ⇄ 255	0–100%
-	-	-	-	16	21	24	24	Amber 3	000 ⇄ 255	0–100%
-	-	-	-	17	22	25	25	White 3	000 ⇄ 255	0–100%
-	-	-	-	18	23	26	26	UV 3	000 ⇄ 255	0–100%
-	-	-	-	-	24	27	27	Strobe 3	000 ⇄ 010 011 ⇄ 255	No function Strobe, slow to fast
-	-	-	-	-	25	28	28	Dimmer 4	000 ⇄ 255	0–100%
-	-	-	-	-	-	29	29	Fine dimmer 4	000 ⇄ 255	0–100%
-	-	-	-	19	26	30	30	Red 4	000 ⇄ 255	0–100%
-	-	-	-	20	27	31	31	Green 4	000 ⇄ 255	0–100%
-	-	-	-	21	28	32	32	Blue 4	000 ⇄ 255	0–100%
-	-	-	-	22	29	33	33	Amber 4	000 ⇄ 255	0–100%
-	-	-	-	23	30	34	34	White 4	000 ⇄ 255	0–100%
-	-	-	-	24	31	35	35	UV 4	000 ⇄ 255	0–100%
-	-	-	-	-	32	36	36	Strobe 4	000 ⇄ 010 011 ⇄ 255	No function Strobe, slow to fast
-	-	-	10	-	-	-	37	Color macro	000 ⇄ 255	See the Color Macro Chart
-	-	-	11	-	-	-	38	Color temperature	000 ⇄ 255	See the Color Temperature Chart
-	-	-	12	-	-	-	39	Automatic program	000 ⇄ 010 011 ⇄ 060 061 ⇄ 110 111 ⇄ 160 161 ⇄ 210 211 ⇄ 255	No function Automatic program 1 Automatic program 2 Automatic program 3 Automatic program 4 Automatic program 5 (cycle 1–4)
-	-	-	13	-	-	-	40	Program speed	000 ⇄ 255	Automatic program speed, slow to fast
-	-	-	14	-	-	-	41	Control	000 ⇄ 255	See the Control Chart

LED Frequency

To adjust the frequency of the pulse width modulation:

1. Go to the **LED Frequency** main level.
2. Select the frequency, from **600Hz**, **1200Hz**, **2000Hz**, **4000Hz**, **6000Hz**, or **25kHz**.

Back Light

To set how long before an inactive display will turn off:

1. Go to the **Back Light** main level.
2. Select the length of the backlight timer, from **10S** (10 seconds), **30S** (30 seconds), **2Min** (2 minutes), or **Always On**.

Information

To view essential product information:

1. Go to the **Information** main level.
2. Select **Fixture Hours**, **Version**, or **UID**.

Factory Reset

To reset the product to factory settings:

1. Go to the **Reset Factory** main level.
2. Select **NO** (to cancel) or **YES** (to reset the product configuration).

5. Maintenance

Product Maintenance

Dust build-up reduces light output performance and can cause overheating. This can lead to reduction of the light source's life and/or mechanical wear. To maintain optimum performance and minimize wear, clean each lighting product at least twice a month. However, be aware that usage and environmental conditions could be contributing factors to increase the cleaning frequency.

To clean the product, follow the instructions below:

1. Unplug the product from power.
2. Wait until the product is at room temperature.
3. Use a vacuum (or dry compressed air) and a soft brush to remove dust collected on the external surface/vents.
4. Clean all transparent surfaces with a mild soap solution, ammonia-free glass cleaner, or isopropyl alcohol.
5. Apply the solution directly to a soft, lint free cotton cloth or a lens cleaning tissue.
6. Softly drag any dirt or grime to the outside of the transparent surface.
7. Gently polish the transparent surfaces until they are free of haze and lint.



Always dry the transparent surfaces carefully after cleaning them.



Do not spin the cooling fans with compressed air. Damage may result.

6. Technical Specifications

Dimensions and Weight

Length	Width	Height	Weight
45.3 in (1150.6 mm)	5.16 in (131 mm)	11.08 in (281.4 mm)	28.8 lb (12.0 kg)

Note: Dimensions in inches are rounded.

Power

Power Supply Type	Range	Voltage Selection
Switching (internal)	100 to 240 VAC, 50/60 Hz	Auto-ranging

Parameter	100 V, 60 Hz	120 V, 60 Hz	208 V, 60 Hz	230 V, 50 Hz	240 V, 50 Hz
Consumption	557 W	551 W	546 W	550 W	559 W
Operating Current	5.55 A	4.63 A	2.63 A	2.41 A	2.33 A
Power Linking Current	12 A	12 A	12 A	12 A	12 A
Fuse	T10AL	T10AL	T10AL	T10AL	T10AL

Power I/O	U.S./Worldwide	UK/Europe
Power Input Connector	Seetronic Powerkon IP65	Seetronic Powerkon IP65
Power Output Connector	Seetronic Powerkon IP65	Seetronic Powerkon IP65
Power Cable plug	Edison	Local plug

Light Source

Type	Color	Quantity
LED Array	RGBAW-UV	1 (per par)

Photometrics

Filter	Beam Angle (1 Par)	Field Angle (1 Par)	Illuminance @ 5 m (1 Par)
No filter	15.3°	30.4°	1,482 lux
Wide filter	29.8°	49.4°	510 lux

Lumens (1 Par)	Lumens (All Pars)
4,305	17,930

Thermal

Maximum External Temperature	Cooling System
113 °F (45 °C)	Fan-assisted Convection

Control

DMX I/O Connector	Channel Range
5-pin XLR, etherCON compatible RJ45	6, 8, 9, 14, 24, 32, 36, or 41

Ordering

Product Name	Item Name	Item Code	UPC Number
COLORdash Par Bar 4	COLORDASHPARBAR4	10032078	781462224264



UL 1573
CSA C22.2 No. 166
E113093



Contact Us

General Information	Technical Support
Chauvet World Headquarters	
Address: 3360 Davie Rd., Suite 509 Davie, FL 33314 Voice: (954) 577-4455 Fax: (954) 929-5560 Toll Free: (800) 762-1084	Voice: (844) 393-7575 Fax: (954) 756-8015 Email: chauvetcs@chauvetlighting.com Website: www.chauvetprofessional.com
Chauvet U.K.	
Address: Pod 1 EVO Park Little Oak Drive, Sherwood Park Nottinghamshire, NG15 0EB UK Voice: +44 (0) 1773 511115 Fax: +44 (0) 1773 511110	Email: UKtech@chauvetlighting.eu Website: www.chauvetprofessional.eu
Chauvet Benelux	
Address: Vaartlaan 9 9800 Deinze Belgium Voice: +32 9 388 93 97	Email: BNLtech@chauvetlighting.eu Website: www.chauvetprofessional.eu
Chauvet France	
Address: 3, Rue Ampère 91380 Chilly-Mazarin France Voice: +33 1 78 85 33 59	Email: FRtech@chauvetlighting.fr Website: www.chauvetprofessional.eu
Chauvet Germany	
Address: Bruno-Bürgel-Str. 11 28759 Bremen Germany Voice: +49 421 62 60 20	Email: DEtech@chauvetlighting.de Website: www.chauvetprofessional.eu
Chauvet Mexico	
Address: Av. de las Partidas 34 - 3B (Entrance by Calle 2) Zona Industrial Lerma Lerma, Edo. de México, CP 52000 Voice: +52 (728) 690-2010	Email: servicio@chauvet.com.mx Website: www.chauvetprofessional.mx

Warranty & Returns

For warranty terms and conditions and return information, please visit our website.

For customers in the United States and Mexico: www.chauvetlighting.com/warranty-registration.

For customers in the United Kingdom, Republic of Ireland, Belgium, the Netherlands, Luxembourg, France, and Germany: www.chauvetlighting.eu/warranty-registration.