

cloud 9XIP

User Manual



Model ID: Cloud 9X IP
220VCloud 9X IP

Edition Notes

The Cloud 9X IP User Manual includes a description, safety precautions, installation, programming, operation, and maintenance instructions for the Cloud 9X IP as of the release date of this edition.

Trademarks

Chauvet, Chauvet Professional, the Chauvet logo, and Cloud 9 are registered trademarks or trademarks of Chauvet & Sons, LLC (d/b/a Chauvet and Chauvet Lighting) in the United States and other countries. Other company and product names and logos referred to herein may be trademarks of their respective companies.

Copyright Notice

The works of authorship contained in this manual, including, but not limited to, all designs, text, and images are owned by Chauvet.

© Copyright 2026 Chauvet & Sons, LLC. All rights reserved.

Electronically published by Chauvet in the United States of America.

Manual Use

Chauvet authorizes its customers to download and print this manual for professional information purposes only. Chauvet expressly prohibits the usage, copy, storage, distribution, modification, or printing of this manual or its content for any other purpose without written consent from Chauvet.

Document Printing

For best results, print this document in color, on letter size paper (8.5 x 11 in), double-sided. If using A4 paper (210 x 297 mm), configure the printer to scale the content accordingly.

Intended Audience

Any person installing, operating, and/or maintaining this product should completely read through the guide that shipped with the product, as well as this manual, before installing, operating, or maintaining this product.

Disclaimer

Chauvet believes that the information contained in this manual is accurate in all respects. However, Chauvet assumes no responsibility and specifically disclaims any and all liability to any party for any loss, damage, or disruption caused by any errors or omissions in this document, whether such errors or omissions result from negligence, accident, or any other cause. Chauvet reserves the right to revise the content of this document without any obligation to notify any person or company of such revision. However, Chauvet has no obligation to make, and does not commit to make, any such revisions.

Document Revision

Go to www.chauvetprofessional.com for the latest version.

Revision	Date	Description
10	04/2026	Updated the hold time for accessing the system settings.

TABLE OF CONTENTS

- 1. Before You Begin** 1
 - What Is Included 1
 - Claims 1
 - Text Conventions 1
 - Symbols 1
 - Safety Notes..... 2
 - RF Exposure Warning for North America and Australia..... 3
- 2. Introduction** 4
 - Features 4
 - Product Overview 5
 - Product Accessories 6
 - Product Dimensions 7
- 3. Setup** 8
 - AC Power 8
 - AC Plug 8
 - Resetting the Breaker 8
 - Control Personalities 8
 - DMX Linking 8
 - DMX Personalities..... 8
 - Remote Device Management..... 8
 - USB Software Update 9
 - Mounting 10
 - Orientation..... 10
 - Mounting Diagram..... 10
 - Hose Attachment..... 11
 - Barbed Hose Adapter Attachment 12
 - Attaching the Pressurized Hose 13
 - Filling The Fluids 14
 - Pressurized Hose 14
 - Reserve Water Reservoir..... 15
 - Fog Fluid Tank 15
- 4. Operation** 16
 - Control Panel Description 16
 - Control Options 16
 - Menu Map 16
 - DMX Configuration 17
 - Starting Address..... 17
 - DMX Channel Assignments and Values 17
 - DMX 17
 - Standalone Configuration..... 18
 - Interval Set 18
 - Duration Set 18
 - Volume Out 19
 - Fan Speed..... 19
 - Humidity 20

DMX 512	20
RDM	21
Auto Run Last Settings	21
Auto-Refill.....	22
Heater	22
Wireless	23
Backlight.....	23
Timed Output Operation.....	24
Volume Output Operation	24
Settings Configuration.....	25
Wireless Remote Configuration	25
5. Maintenance.....	26
Fog Machine Maintenance.....	26
Storage.....	26
6. Technical Specifications	27
Contact Us	28
Warranty & Returns.....	28

Before You Begin

1. Before You Begin

What Is Included

- Cloud 9X IP
- Seetronic Powerkon IP65 power cable
- RF remote (2-button)
- Barbed hose adapter, 0.5 in (13 mm) diameter
- 2 pcs. Barbed hose adapter hose clamp, 1 in (25 mm) diameter
- 6ft (2 m) output hose, 5 in (130 mm) diameter
- Hose coupler, 5 in (130 mm) diameter
- Floor nozzle, 5 in (130 mm) diameter
- 2 pcs. hose clamps, 6 in (152 mm) diameter
- Removable rear cover
- Overfill hose, polyurethane, 6 mm OD, 4 mm ID, 80 in (204 cm)
- Quick Reference Guide

Claims

Carefully unpack the product immediately and check the container to make sure all the parts are in the package and are in good condition.





If the box or the contents (the product and included accessories) appear damaged from shipping, or show signs of mishandling, notify the carrier immediately, not Chauvet. Failure to report damage to the carrier immediately may invalidate a claim. In addition, keep the box and contents for inspection.

For other issues, such as missing components or parts, damage not related to shipping, or concealed damage, file a claim with Chauvet within 7 days of delivery.

Text Conventions

Convention	Meaning
1–512	A range of values
50/60	A set of values of which only one can be chosen
Settings	A menu option not to be modified
<ENTER>	A key to be pressed on the product's control panel

Symbols

Symbol	Meaning
	Electrical warning. Not following these instructions may cause electrical damage to the product, accessories, or the user.
	Critical installation, configuration, or operation information. Not following these instructions may make the product not work, cause damage to the product, or cause harm to the operator.
	Pinch point warning. Not following these instructions may result in damage to, or loss of, tools, digits, or limbs.
	Important installation or configuration information. The product may not function correctly if this information is not used.
	Useful information.



Any reference to data or power connections in this manual assumes the use of Seetronic IP-rated cables.

The term “DMX” used throughout this manual refers to the USITT DMX512-A digital data transmission protocol.



Connection of the control signal: DMX line

- The product has XLR sockets for DMX input and output.
- **Notice:** This control circuit is isolated and belongs to the Class 2 data port.

The control circuit has a cumulative leakage current of less than 3.5 mA.

Safety Notes

Read all the following safety notes before working with this product. These notes contain important information about the installation, usage, and maintenance of this product.



This product contains no user-serviceable parts. Any reference to servicing in this User Manual will only apply to properly trained, certified technicians. Do not open the housing or attempt any repairs.



All applicable local codes and regulations apply to proper installation of this product.

- If the external flexible cable or cord of this product is damaged, it shall be replaced by a special cord or cord exclusively available from the manufacturer or its service agent.
- **CAUTION:**
 - This product's housing may be hot when operating. Mount this product in a location with adequate ventilation, at least 20 in (50 cm) from adjacent surfaces.
 - When transferring the product from extreme temperature environments, (e.g., cold truck to warm humid ballroom) condensation may form on the internal electronics of the product. To avoid causing a failure, allow the product to fully acclimate to the surrounding environment before connecting it to power.
 - Condensation from emitted fog may form on the floor around the output nozzle. Use caution when walking in this area.
- **ALWAYS:**
 - When using an IP65-rated product in an outdoor environment, use IP65- (or higher) rated power and data cable.
 - Replace and secure IP-rated protective covers to all power, data, USB, or other ports when not in use.
 - Connect this product to a grounded and protected circuit.
 - Drain the tank before transporting the product.
- **DO NOT:**
 - Open this product. It contains no user-serviceable parts.
 - Leave any flammable material within 30 cm of this product while operating or connected to power.
 - Connect this product to a dimmer or rheostat.
 - Operate this product if the housing, hoses, fluid tank, or cables appear damaged.
 - Submerge this product (adhere to standards for the published IP rating). Regular outdoor operation is fine.
 - Permanently install outdoors in locations with extreme environmental conditions. This includes, but is not limited to:
 - Exposure to a marine/saline environment (within 3 miles of a saltwater body of water).
 - Locations where normal temperatures exceed the temperature ranges in this manual.
 - Locations that are prone to flooding or being buried in snow.
 - Other areas where the product will be subject to extreme radiation or caustic substances.
 - Use for space-heating purposes.
 - Touch the output nozzle on this product. It is very hot during operation, and it may remain hot for several hours after turning the product off.
 - Add anything to the fluid.
 - Drink the fluid.
 - Allow the fluid to contact skin or eyes.
- ONLY use approved Chauvet fluids.
- Depending on the amount of fog/haze generated, all fog/haze machines may set off smoke detectors.
- The maximum ambient temperature is 113 °F (45 °C). Do not operate this product at higher temperatures.
- The minimum startup temperature is -4°F (-20°C). Do not start the product at lower temperatures.
- The minimum ambient temperature is -4°F (-20°C). Do not operate the product at lower temperatures.
- To eliminate unnecessary wear and improve its lifespan, during periods of non-use completely disconnect the product from power via breaker or by unplugging it.
- In the event of a serious operating problem, stop using immediately.



Before You Begin



This machine is designed for use with clean, potable water only. Using untreated, contaminated, or questionable water may result in reduced performance, damage to the unit, or potential health hazards. If you are unsure of your water quality, use bottled or distilled water. Always empty the water tank after use and allow the machine to dry. Failure to clean and drain the unit may cause bacterial growth, odors, or damage internal components.



If this Chauvet product requires service, contact Chauvet Technical Support.

RF Exposure Warning for North America and Australia

Warning! This equipment complies with FCC radiation exposure limits set forth for an uncontrolled environment. This equipment should be installed and operated with a minimum distance of 20 cm between the radiator and the user. This transmitter must not be co-located or operating in conjunction with any other antenna or transmitter.

2. Introduction

Features

- Compact, professional fogger gives high-impact low-lying fog effect on stage or in ballrooms
- Suitable for temporary outdoor/wet use
- Continuous operation produces fog to cover 3,230 ft² (300 m²) area
- Ultrasonic agitators combine water with fog (produced from fog fluid) to create low-lying fog effect
- Ships in integrated, rugged flight case with locking casters suitable for rental/touring applications with removeable cover for rear panel
- Control via on board full color display, wireless (RF) handheld remote, or DMX
- Integrated water drainage system makes cleanup fast and easy
- Use the low-lying fog fluid (LLG) to produce the CO² effect, which lasts for several minutes before dissipating
- Use without dry ice or CO₂, so no special licensing/training required
- USB-C slot for software uploads

Introduction

Product Overview

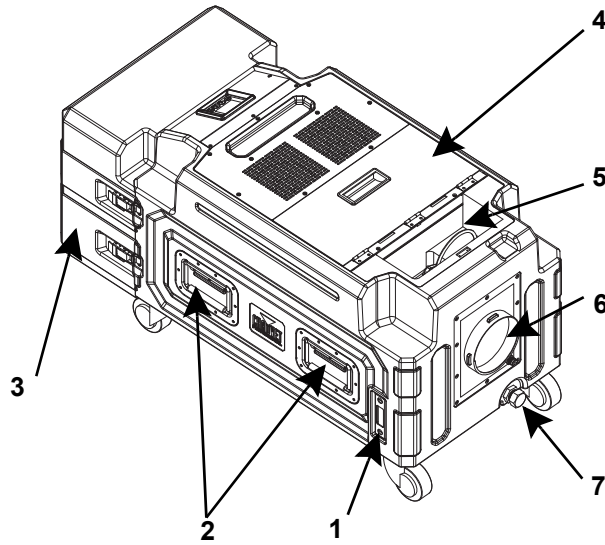

#	Name	#	Name
1	Fluid level indicator	10	5-pin DMX in/out
2	Handles (x4)	11	3-pin DMX in/out
3	Rear cover	12	Power switch
4	Reserve water reservoir	13	Breaker
5	Fog fluid tank	14	USB-C port
6	Output nozzle	15	120/230V Power in
7	Drainage valve	16	Input nozzle
8	LCD Display	17	Primary water tank
9	Menu buttons		

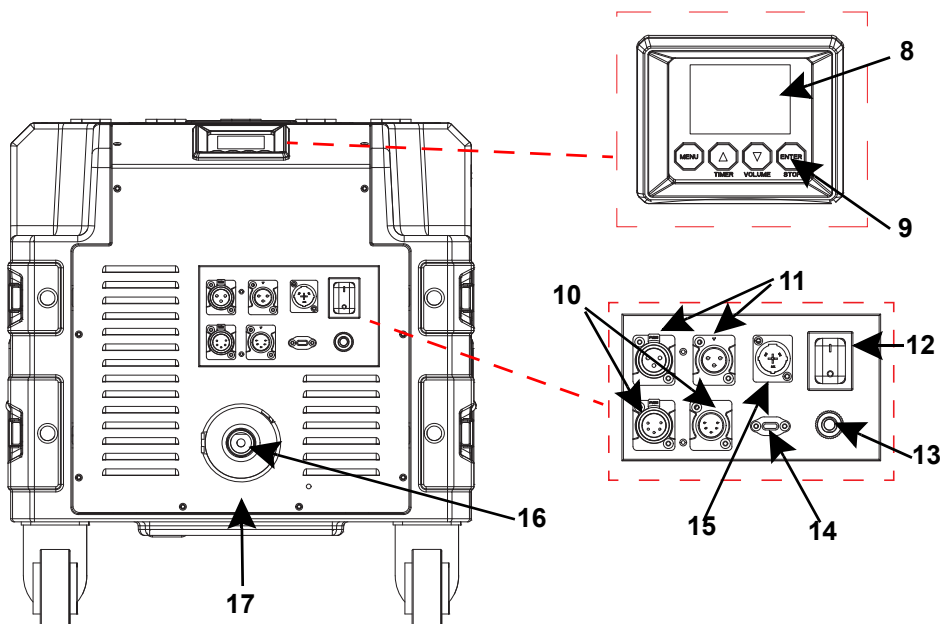

Product Accessories

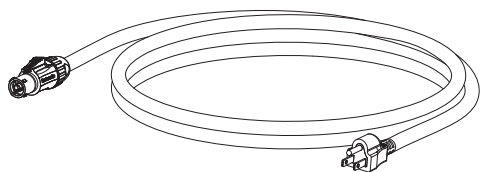

1

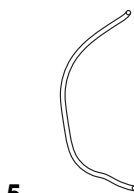

5

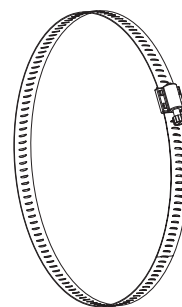

8

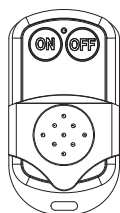

2

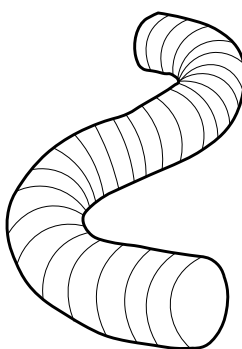

6

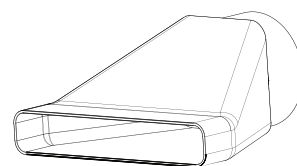

9

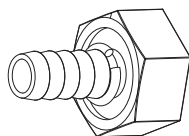

3

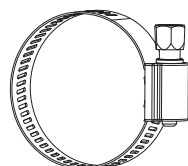

4

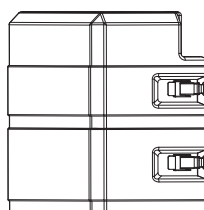

7

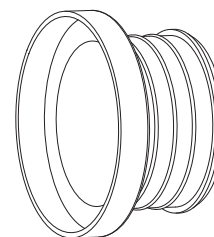

10

#	Name	#	Name
1	Seetronic powerKon IP65 power cable	6	6 ft. (2 m) output hose, 5 in (130 mm) diameter
2	RF remote (2-button)	7	Removable rear cover
3	Barbed hose adapter, 0.5 in (13 mm) diameter	8	2 pcs. hose clamps, 6 in (152 mm) diameter
4	2 pcs. barbed hose adapter clamp, 1 in (25 mm) diameter	9	Floor nozzle, 5 in (130 mm) diameter
5	Overfill hose, polyurethane, 6 mm OD, 4mm ID, 80 in (204 cm)	10	Hose coupler, 5 in (130 mm) diameter

Product Dimensions

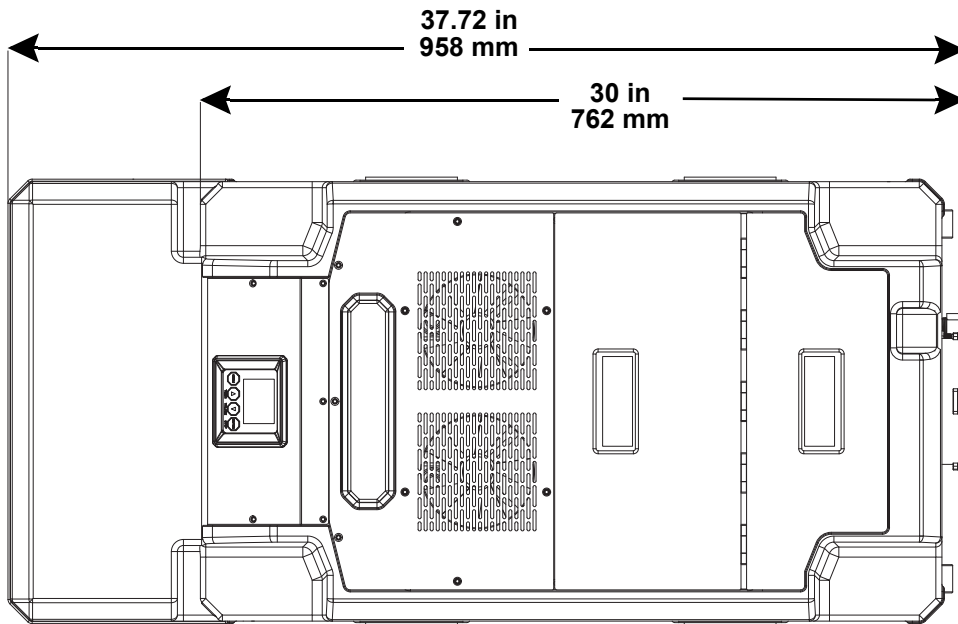
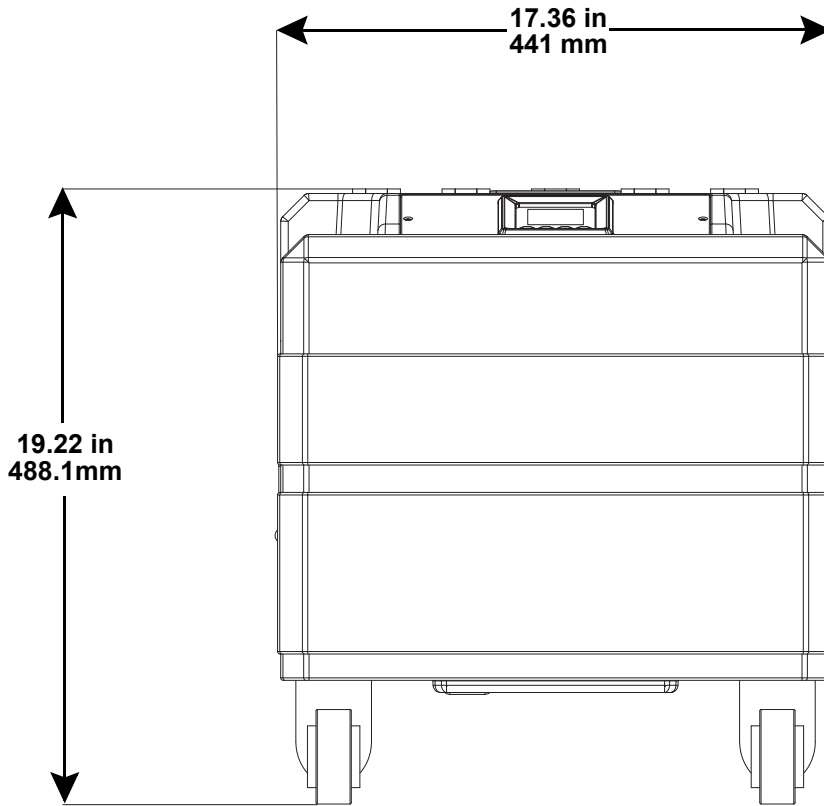

3. Setup

AC Power

The Cloud 9X IP has a fixed power supply that works with an input voltage of either 120 VAC, 60 Hz or 230 VAC, 50 Hz, depending on the specific model.

To determine the product's power requirements (circuit breaker, power outlet, and wiring), use the current value listed on the label affixed to the product's back panel, or refer to the product's specifications chart. The listed current rating indicates the product's average current draw under normal conditions.



- **Always connect the product to a protected circuit (a circuit breaker or fuse). Ensure the product has an appropriate electrical ground to avoid the risk of electrocution or fire.**
- **To eliminate unnecessary wear and improve its lifespan, during periods of non-use completely disconnect the product from power via breaker or by unplugging it.**



Never connect the product to a rheostat (variable resistor) or dimmer circuit, even if the rheostat or dimmer channel serves only as a 0 to 100% switch.

AC Plug

The Cloud 9X IP comes with a power input cable terminated with a Seetronic Powerkon A connector on one end and an Edison plug on the other end (U.S. market). If the power cable which came with the product has no plug, or if it is necessary to change the plug, use the table below to wire a plug.

Connection	Wire (U.S.)	Wire (Europe)	Screw Color
AC Live	Black	Brown	Yellow or Brass
AC Neutral	White	Blue	Silver
AC Ground	Green/Yellow	Green/Yellow	Green

Resetting the Breaker

This product is equipped with a resettable circuit breaker. If the breaker trips, all sections of this product will lose power.

1. Remove the power cord from main power.
2. Allow unit to cool for 15 minutes.
3. After 15 minutes, user may attempt to reset the breaker by pressing the button with their finger.
4. Plug the product's power cord into the power outlet and continue using as recommended.

Control Personalities

The Cloud 9X IP uses a 3- or 5-pin DMX data connection for its 1 control personality.



If the user is not familiar with or need more information about DMX standards or the DMX cables needed to link this product to a DMX controller, download the DMX Primer from the Chauvet website: www.chauvetprofessional.com.

DMX Linking

The Cloud 9X IP can be linked to a DMX controller using a 3- or 5-pin DMX connection. If using other DMX-compatible products with this product, it's possible to control each individually with a single DMX controller.

DMX Personalities

The Cloud 9X IP uses a 3- or 5-pin DMX data connection for its for **3Ch** DMX personality.



For information about DMX standards, Master/Slave connectivity, or the DMX cables needed to link this product to a DMX controller, download the DMX Primer from the Chauvet website: www.chauvetprofessional.com.

Remote Device Management

Remote Device Management, or RDM, is a standard for allowing DMX-enabled devices to communicate bi-directionally along existing DMX cabling. Check the DMX controller's User Manual or with the manufacturer as not all DMX controllers have this capability. The Cloud 9X IP supports RDM protocol that allows feedback to make changes to menu map options.

USB Software Update

The Cloud 9X IP allows for software updates with a USB device using the built-in USB port. To update the software using a USB type C flash drive, do the following:

1. Download the latest software file, APP-OUTDOOR-CLOUD9.bin, onto the root directory of a formatted USB-C flash drive. To locate the file, visit <https://github.com/Chauvet-Pro>.



- **The product's USB port supports up to 32GB capacity and only works with FAT32 file format.**
- **Once the file has been downloaded, the filename cannot be changed.**

2. Insert the USB-C flash drive into the USB-C port of the Cloud 9X IP and turn on the product.
3. On the display screen, a progress bar will appear to indicate the status of the ongoing update. The progress is also display as a numerical percentage. Allow time for the software update to be completed.
4. Once the update is complete, a prompt will appear on the display screen to indicate a successful software update.



The display screen may show an update summary such as APP CONTROL UPDATE, MCU IAP No Update, and Update Success.

5. The screen will then display the starting menu.
6. Remove the USB-C flash drive from the product.

Mounting

Before mounting the product, read and follow the safety recommendations indicated in the [Safety Notes](#).

Orientation

Always mount this product in a safe position, making sure there is adequate room for ventilation, configuration, and maintenance

Mounting Diagram

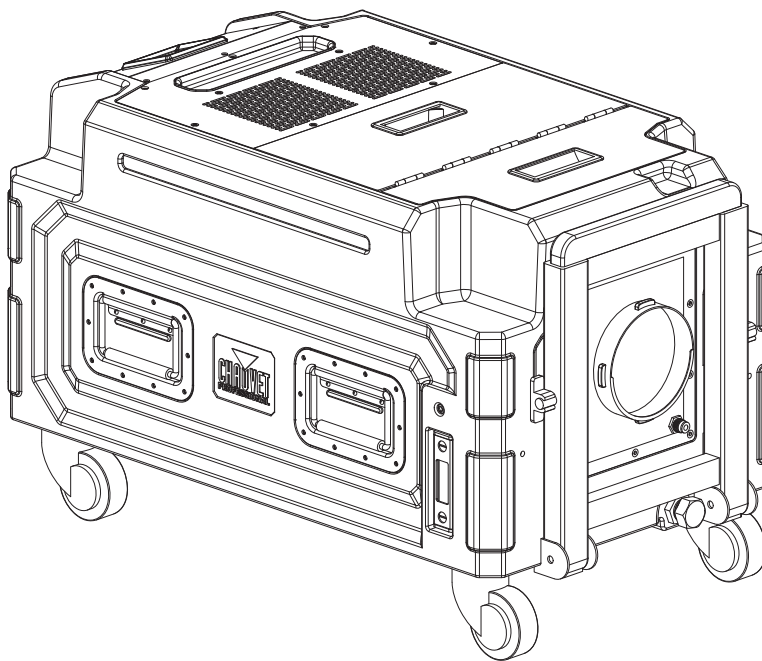

Surface Mount

Stacking Diagram

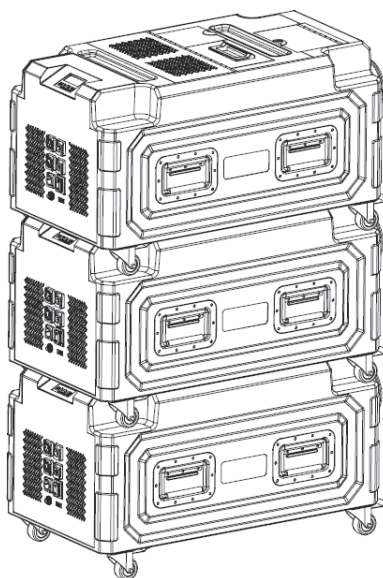

Stack Mount



When stack mounting the Cloud 9X IP, do not exceed more than 3 products. Stacking units beyond this total may result in serious injury or damage.

Setup

Hose Attachment

The Cloud 9X IP comes with a hose coupler, an output hose, and a clamp that attaches to the nozzle for a low-lying fog effect. To attach or remove the hose, use the hose coupler to secure the directional hose to the nozzle.

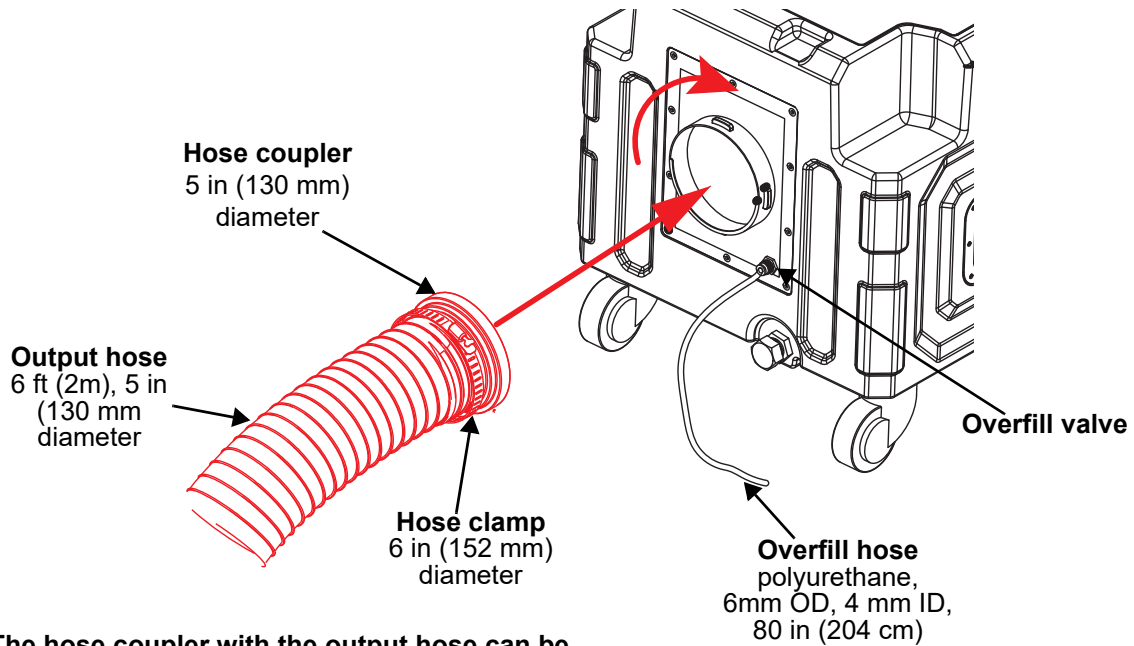

* The hose coupler with the output hose can be attached to the unit with a $\frac{1}{4}$ turn.

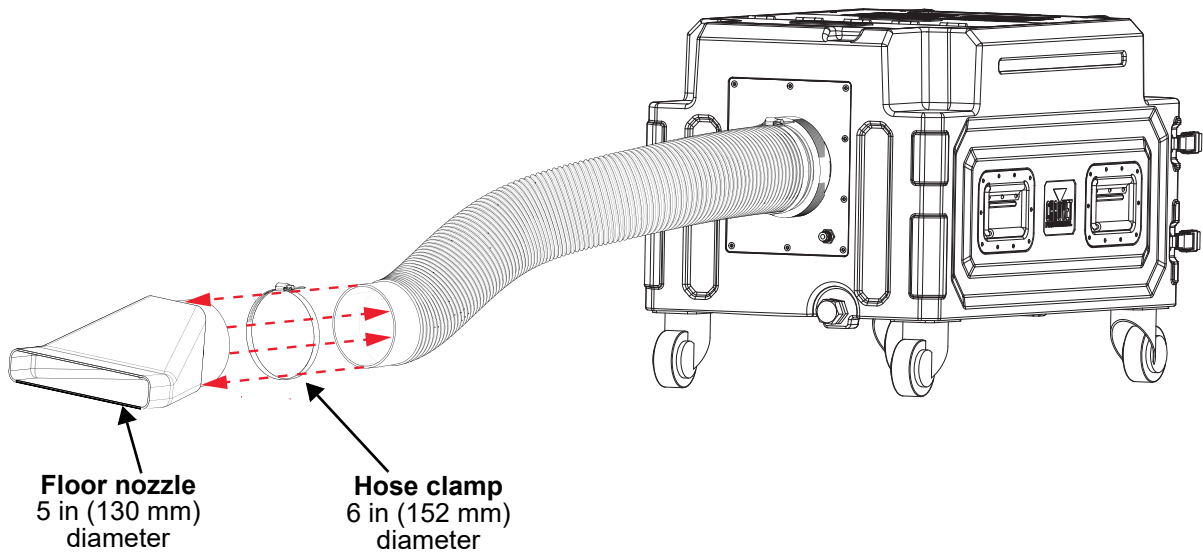

Tilting the unit may cause internal water migration and system malfunction. This product should be level while operating. Drain all the water before transporting or storing.

Barbed Hose Adapter Attachment

The Cloud 9X IP comes with a barbed hose adapter that attaches to the input nozzle for easy filling of the product's primary water tank.

1. Attach the barbed hose adapter to the product by turning it clockwise onto the input nozzle.
2. Attach a pressurized water line (not included) to the barbed end of the adapter to begin filling the primary water tank, without the use of a water pump.

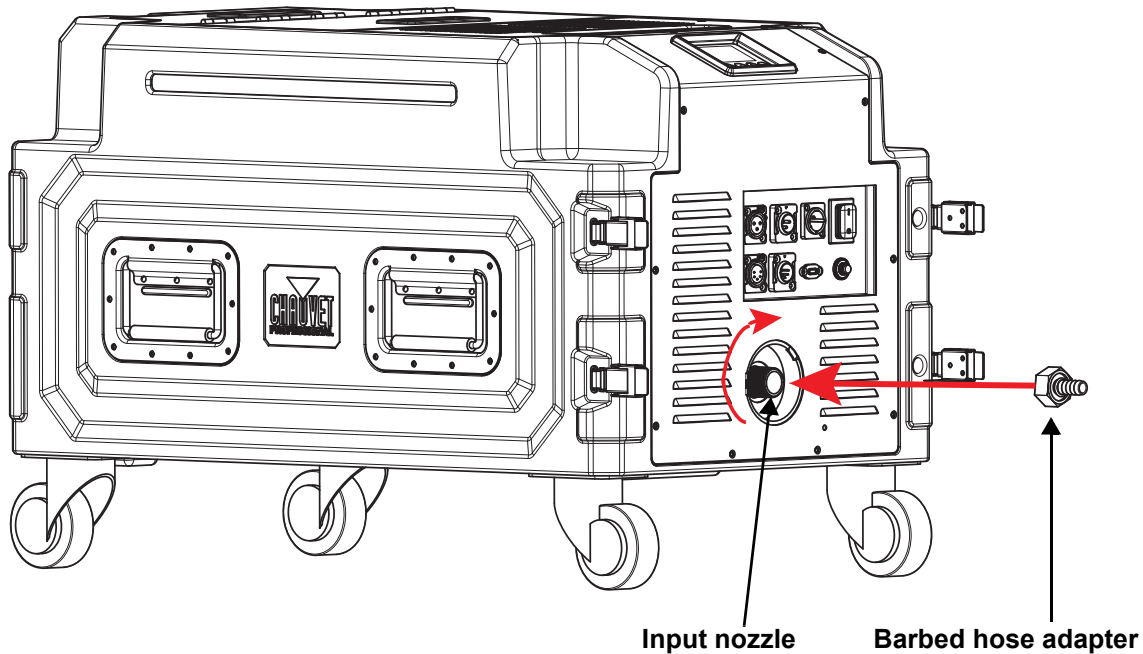

The Cloud 9X IP does not contain an onboard water pump. The unit's internal water tank can be refilled by using a pressurized water line.



When filling the primary water tank using a pressurized water line, the Auto-refill menu option on the Main Menu must be turned on to enable continued automatic filling of the tank.

Attaching the Pressurized Hose

1. Loosen the included hose clamp with a #2 Philips head screwdriver to the diameter of the hose.
2. Slide the clamp over the bare ended hose.
3. Apply a petroleum based lubricant to the internal tip of the hose for easier attachment to the barbed hose adapter.
4. Slide the hose over the barbed hose adapter until fully seated.
5. Slide the hose clamp over the hose and place it over the barbed hose adapter to apply tension.
6. Using a #2 Philips screwdriver, tighten the hose clamp onto the barbed hose adapter.

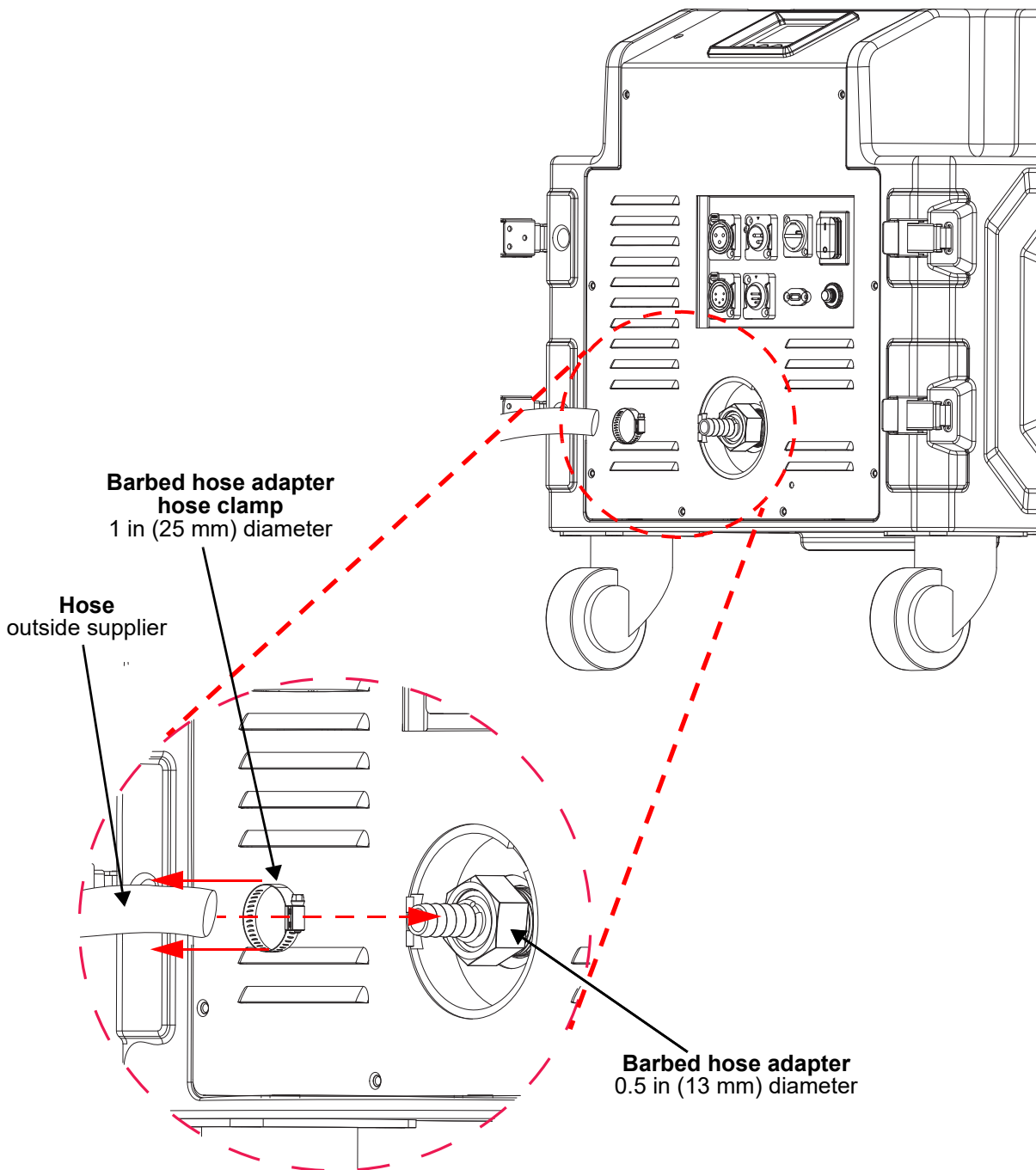

Filling The Fluids

The Cloud 9X IP has a primary water tank, a reserve water reservoir, and a fog fluid tank. These must all be filled before operating the unit.

The primary water tank can be filled using two options:

1. Filling the [Reserve Water Reservoir](#).
2. Using a [Pressurized Hose](#) connected to the barbed hose adapter.

Pressurized Hose

To fill the primary water tank:

1. Attach the barbed hose adapter to the input nozzle.
2. Using the included hose clamp, clamp a pressurized water hose onto the barbed end of the hose adapter.
3. Begin filling the unit with water.

Pressurized water hose

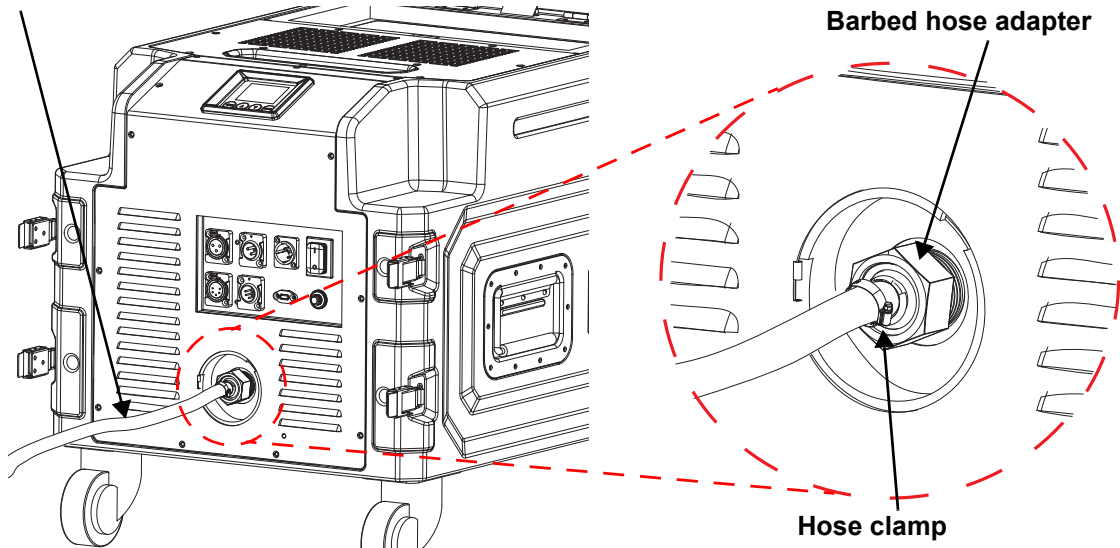

4. Fill the primary water tank until the water reaches the **MAX** level line on the indicator.

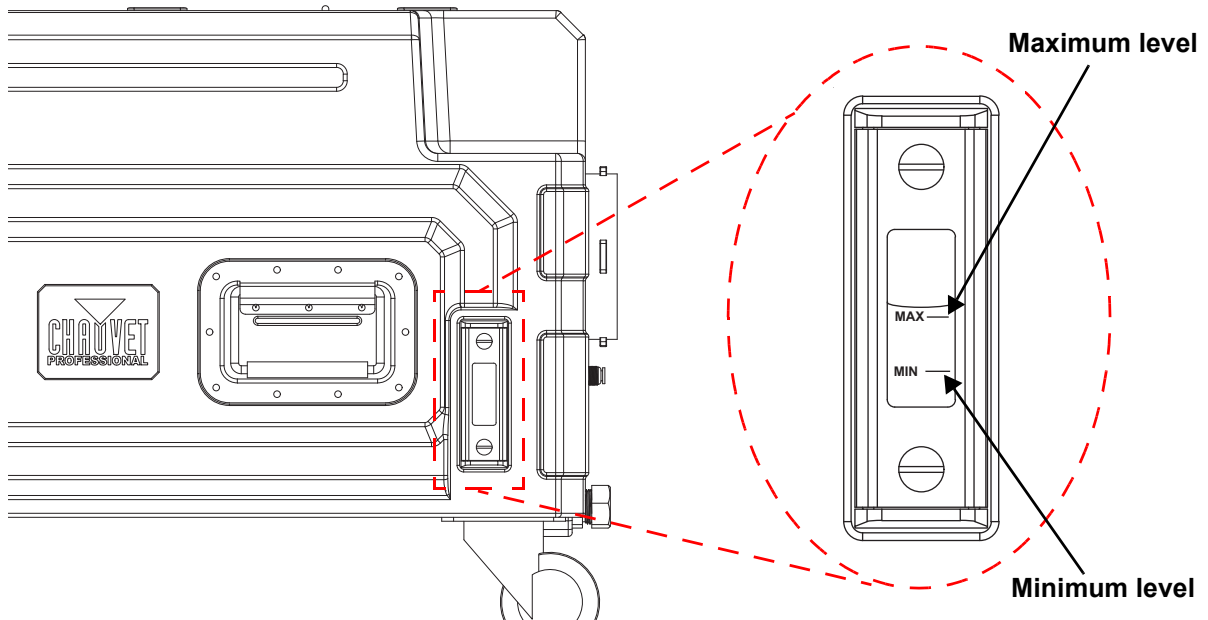

The fluid level indicator is a representation of the physical water level in the primary water tank. It does not connect to the electrical sensor which will cause the unit to start or stop operating depending on the amount of water in the primary water tank.

Reserve Water Reservoir

To fill the primary water tank using the reserve water reservoir:

1. Open the reservoir refill cover.
2. Pour water into the reservoir until maximum capacity of the primary water tank has been reached. A valve will close off the primary water tank's opening.
3. Continue adding water to the reservoir until it completely fills, up to 2 gallons.
4. Close the reservoir refill cover.

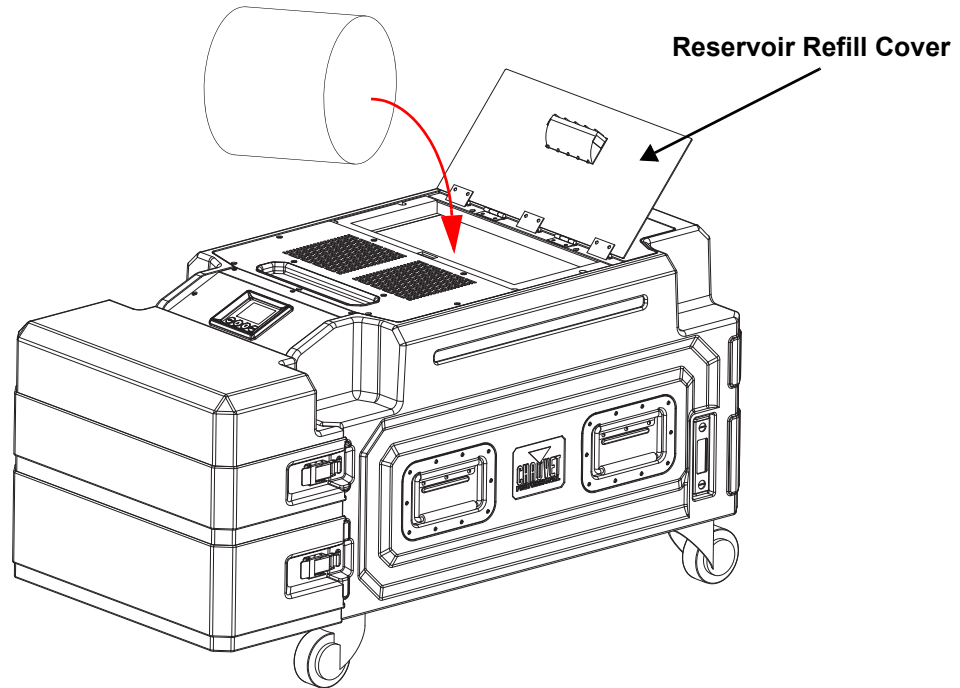

Fog Fluid Tank

To fill the fog fluid tank:

1. Open the fog fluid refill cover.
2. Open the fog fluid tank.
3. Fill the tank with LLG or LLFS (EU) fluids.
4. Close the fog fluid tank ensuring the fluid hose is inside the tank.
5. Close the fog fluid refill cover.

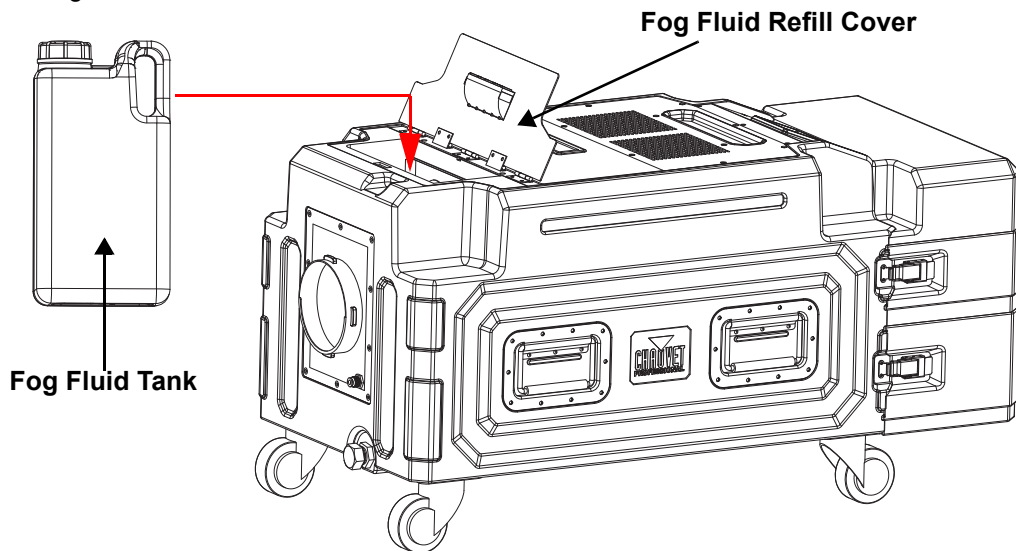

4. Operation

Control Panel Description

Button	Function
<MENU>	Exits from the current menu or function
<UP/TIMER>	UP navigates upwards through the menu list and increases the numeric value when in a function. TIMER starts the timer controlled operation.
<DOWN/VOLUME>	DOWN navigates downwards through the menu list and decreases the numeric value when in a function. VOLUME triggers the pump to modify the output volume.
<ENTER/STOP>	ENTER enables the currently displayed menu or sets the currently selected value into the selected function. STOP turns the fog output off.

Control Options

Set the Cloud 9X IP starting address in the **001-510** DMX range. This enables control of up to 32 products in the 3-channel personality.

Menu Map

Refer to the Cloud 9X IP product page on www.chauvetprofessional.com for the latest menu map.

Main Level	Programming Levels	Description
INTERVAL SET	5-600S	Sets the interval fog output time
DURATION SET	5-300S	Sets the continuous fog output time
VOLUME OUT	1-100%	Sets the fog volume output
FAN SPEED	0-100%	Sets the air volume output. Fan stops at 0
HUMIDITY	OFF	Selects the atomizer performance mode for water vapor output
	MINIMUM	
	MEDIUM	
	MAXIMUM	
DMX 512	1-510	Selects the DMX starting address
RDM-UID	-----	Unique RDM identification number
AUTO RUN LAST SETTINGS	ON	Automatically sets the values to previous selections
	OFF	
AUTO-REFILL	ON	Enables/disables the water refill function when an external water line is connected. Auto-refill function will only work with a pressurized water line.
	OFF	
HEATER	ON	Enables or disables the fog heater circuit
	OFF	
WIRELESS PAIRING	ON	Activates the pairing function for wireless device
	OFF	
	PAIRING	Begins process of pairing the product with the wireless device
BACKLIGHT TIMER	OFF	Turns off the timer for the LCD display backlight
	10 s	Display turns off after 10 seconds
	30 s	Display turns off after 30 seconds
	2 MIN	Display turns off after 2 minutes

Operation

DMX Configuration

Use control configurations to operate the product with a DMX controller.



- See the [Starting Address](#) section for the highest selectable starting address for each personality.
- Make sure that the starting addresses on the various products do not overlap due to the new personality setting.

Starting Address

Each product will respond to a unique starting address from the controller. All products with the same starting address will respond in unison. To set the starting address in DMX mode:

1. Go to the **DMX 512**.
2. Select the starting address (**001–510**).

Personality	Highest Address
1 Ch	510



Connecting a DMX controller to the Cloud 9X IP will automatically navigate to the DMX Starting Address menu.

DMX Channel Assignments and Values

DMX

Channel	Function	Value	Percent/Setting
1	Fan Speed	000 ⇔ 010	No function
		011 ⇔ 255	1–100%, slow to fast
2	Fog Output	000 ⇔ 010	No function
		011 ⇔ 255	1–100%, thin to heavy
3	Atomizer	000 ⇔ 010	No function
		011 ⇔ 255	1–100%, thin to heavy



The atomizer combines the water with the fog fluid (LLG) to produce a low-lying fog effect. Channels 2 and 3 should be used in unison to successfully achieve this effect.

Standalone Configuration

Use standalone configuration to operate the product without a DMX controller. Press menu repeatedly to cycle through each option.

Interval Set

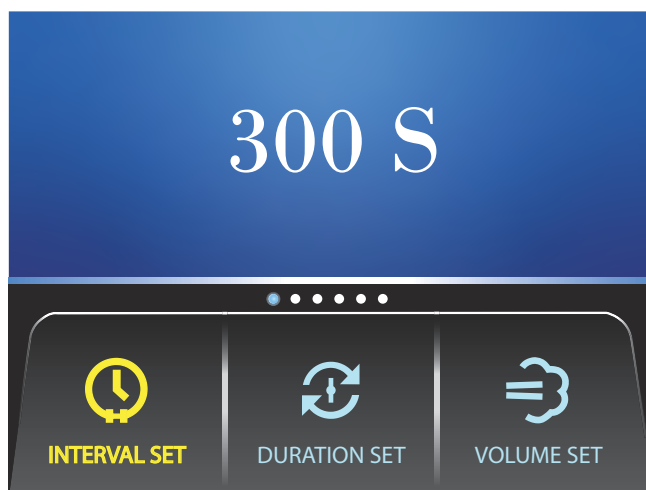

Press **<UP>** or **<DOWN>** to select the interval fog output time from **(5-600 S)**

Duration Set

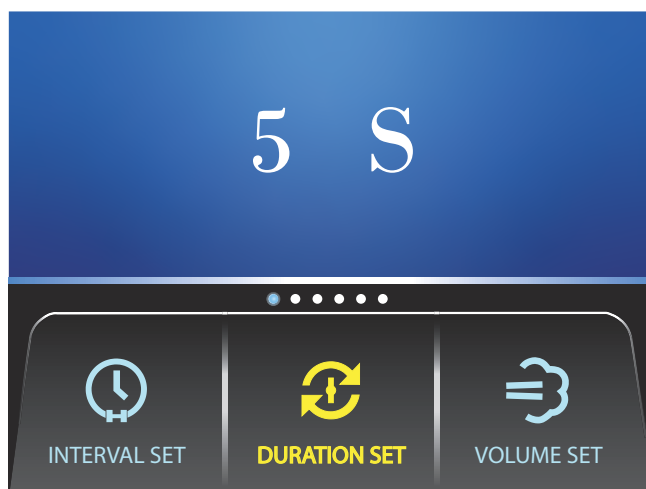

Press **<UP>** or **<DOWN>** to select the continuous fog output time from **(5-300S)**.

Operation

Volume Out

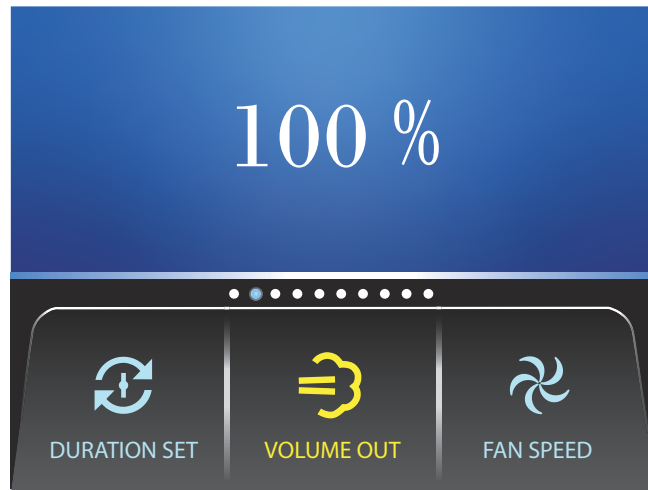

Press **<UP>** or **<DOWN>** to select the fog output from **1-100%**.

Fan Speed

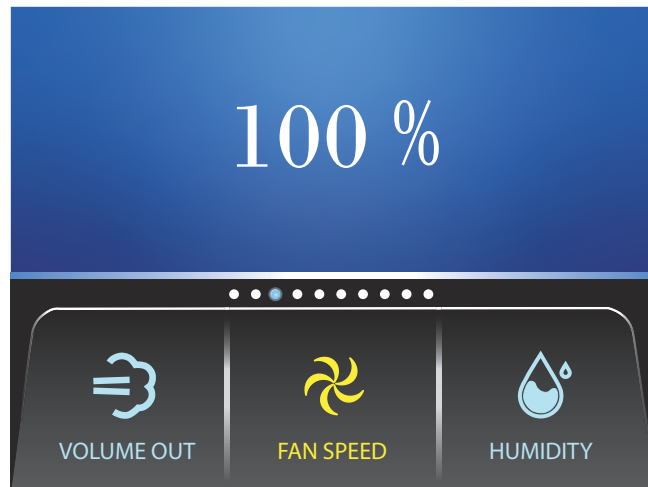

Press **<UP>** or **<DOWN>** to select the fan speed from **0-100%**. The fan stops working when the value is at **0**.

Humidity

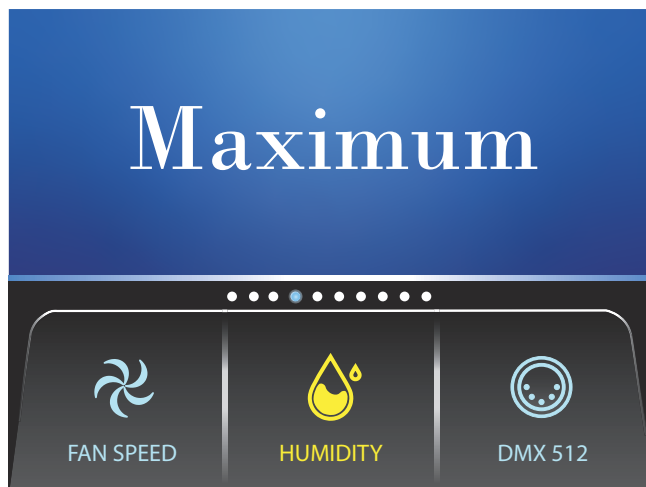

Press <UP> or <DOWN> to select the humidity output from **OFF**, **Minimum**, **Medium**, or **Maximum**.

DMX 512

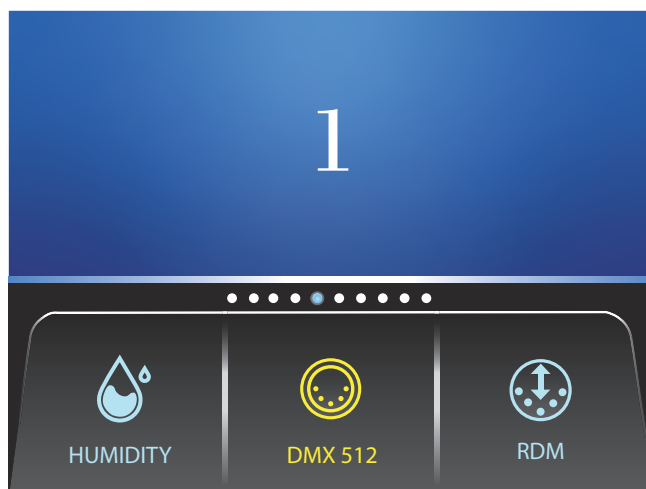

Press <UP> or <DOWN> to select the starting address from **1-510**.

RDM



The current RDM ID will appear on the screen.

Auto Run Last Settings

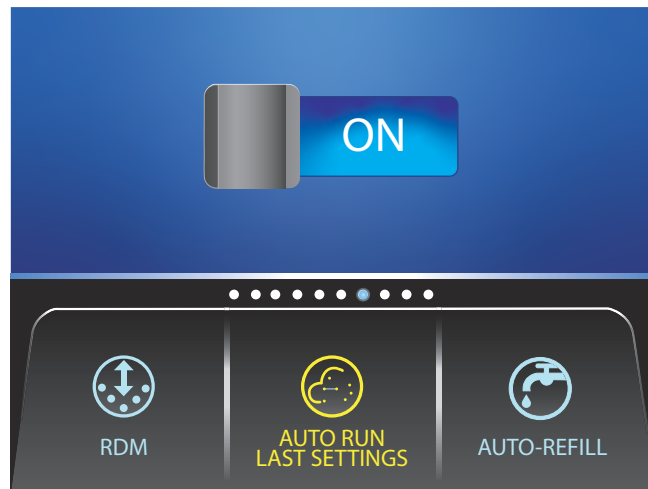

Restore the product to the last working state after a power failure and restart by pressing <UP> or <DOWN> to select from OFF or ON.

Auto-Refill

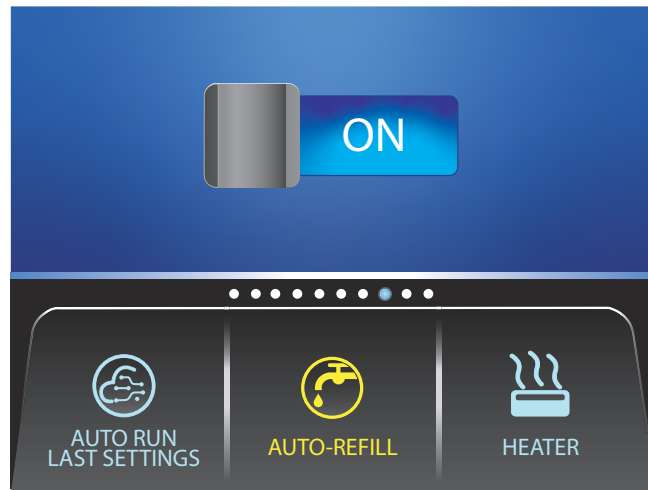

Program the auto-refill feature when an external hose is connected to the Cloud 9X IP by pressing **<UP>** or **<DOWN>** to select from **OFF** or **ON**. Auto-refill requires a pressurized water source connected to the input nozzle.

Heater



Press **<UP>** or **<DOWN>** to select from **OFF** or **ON**.

Operation

Wireless

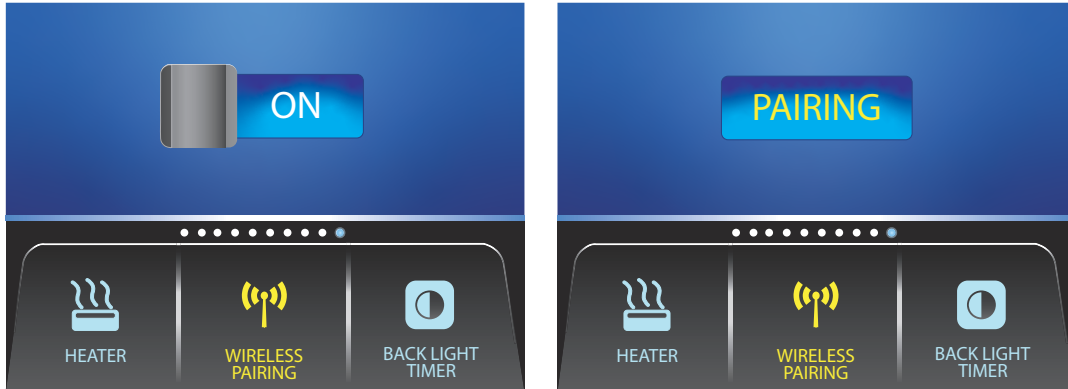

Pair the Cloud 9X IP to the wireless remote by pressing **<UP>** or **<DOWN>**. Press and hold the **<ON>** button of the remote when the **<PAIRING>** screen appears.

Backlight

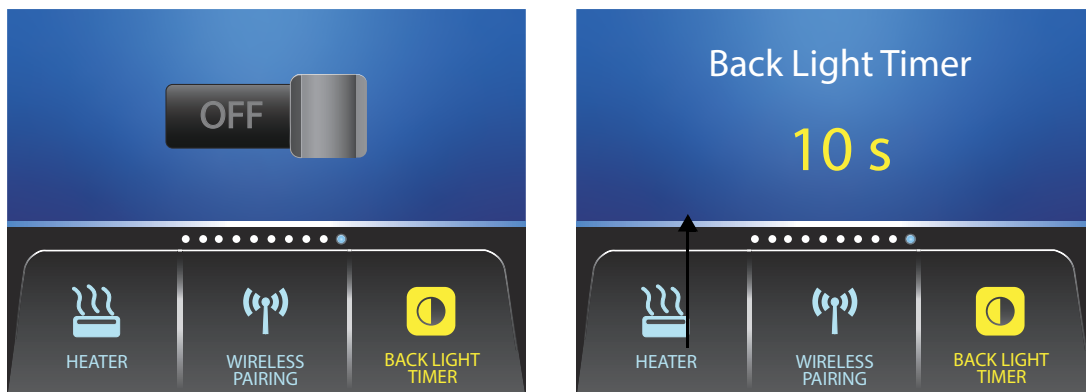

Control the time duration of the backlight for the LCD display by pressing **<UP>** or **<DOWN>** to select from **OFF, 10 s, 30 s, or 2 MIN.**

Timed Output Operation

The Cloud 9X IP offers a timed output operation shortcut screen, which allows easier access to some stand alone functions. To navigate to the Timed Output Operation screen, press **<TIMER>**:



Press **<Menu>** repeatedly to select from **Interval**, **Duration**, **Volume Out**, **Fan Speed**, or **Humidity Out**. Press **<UP>** or **<DOWN>** to select the desired value.

Volume Output Operation

The Cloud 9X IP offers a volume output operation shortcut screen, which allows easier access to some stand alone functions. To navigate to the Output Operation screen, press **<VOLUME>**:



Press **<Menu>** repeatedly to select from **Volume Out** or **Fan Speed**. Press **<UP>** or **<DOWN>** to select the desired value.

Operation

Settings Configuration

The Cloud 9X IP allows for user calibration of the product's system settings. To navigate to setting screen, press and hold **<Menu>** for 5 seconds:

Heater Temperature	252	
High Temperature	260	
Low Temperature	180	
Pump Initial	19	
Water Sensor	ON	
Volume Out	Fan Speed	Humidity Out
100%	100%	Max

Fluid Sensor	ON
Buzzer Out	OFF
Heater Time	2H16M
Running Time	21H5M

Press **<Menu>** repeatedly to scroll through the menu options. Press **<UP>** or **<DOWN>** to select the desired value. Press and hold **<Menu>** for 5 seconds to return to the main menu.

Wireless Remote Configuration

To pair the included wireless remote, follow the instructions in the [Wireless](#) section.

Wireless Remote Operation

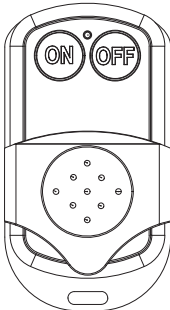
RF	Button	Function
	<ON>	Enables on fog output.
	<OFF>	Disables fog output

To run the Cloud 9X IP with the wireless remote:

1. Press **<ON>** on the wireless remote.
2. To stop output, press **<OFF>** on the wireless remote.



The wireless remote can be paired with multiple units at the same time to achieve a synchronized fog effect.

5. Maintenance

Fog Machine Maintenance

Proper maintenance of Chauvet atmospheric products will increase the reliability and lifespan of products. Maintenance should be completed every 30-90 days, depending on how frequently products are used.



- **When performing maintenance, use Chauvet Fog Cleaner Quart (FCQ) for U.S., or the cleaning Fluid 250 (CF250) for EU products. Run the fluid through the system to reduce the accumulation of particulate matter in the heating element.**
- **DO NOT allow the atmospheric product to become clogged. Once a product is clogged, the cleaning procedure is unlikely to effectively clear the clog.**

The recommended cleaning procedure is as follows:

1. Unplug the product from power.
2. Remove the hose from the fluid tank/reservoir. Remove the FCQ/CF250 screw cap and place the hose in the Fog Cleaner bottle.
3. Connect the product to power and allow it to warm up (if not already warmed up).
4. Run the FCQ/CF250 through the product in a well-ventilated area for 60-90 seconds of continuous, full output.



DO NOT allow the product to run dry!

5. Move the hose from the FCQ/CF250 to a small bottle with water. Run the water through the product for at least 30 seconds to clear any remaining cleaning solution from the pump and heater.



- **Turn off the product when not in use or when storing.**
- **DO NOT leave the cleaning solution in the product.**
- **DO NOT operate the product without fluid at any time.**
- **DO NOT leave Chauvet atmospheric fluid in the product tank/reservoir for more than 10 days without use.**



Fog Cleaner Quart (FCQ) and Cleaning Fluid 250 (CF250) were specifically developed by Chauvet to clean Chauvet atmospheric products equipped with heaters. Use FCQ/CF250 regularly, no longer than 90 days between cleanings (30-60 days if the product is used more frequently), to prevent shortening the life of the product.

Storage

Before storing the Chauvet atmospheric product, run FCQ/CF250 through the system as described in the cleaning procedure above and do not refill the tank with atmospheric fluid before storing the product.



Test-run the Chauvet atmospheric products monthly to achieve the best performance.

Chauvet does not guarantee products will withstand storage for long durations, even if the cleaning process is followed. Please use caution and test regularly to ensure the product continues to function properly.

Technical Specifications

6. Technical Specifications

Dimensions and Weight

Length	Width	Height	Weight
37.72 in (958 mm)	17.36 in (441 mm)	19.22 in (488.1 mm)	76.6 lb (34.75 kg)

Note: Dimensions in inches are rounded.

Power

Power Supply Type	Range	Voltage Selection
Fixed	230 VAC, 50 Hz 120 VAC, 60 Hz	Fixed

Parameter	120 V, 60 Hz	230 V, 50 Hz
Consumption	1960 W	1281 W
Operating Current	17.5 A	5.59 A
Breaker	10 A, 250 V	10 A, 250 V

Power I/O	U.S./Worldwide	UK/Europe
Power Input Connector	Seetronic Powerkon IP65	Seetronic Powerkon IP65
Power Cable plug	Edison	Local plug

Operation/Capacity/Consumption

Heat-up Time	Required Accessories
5 minutes	LLG

Fog Fluid Tank Capacity	Primary Water Tank Capacity	Reserve Water Tank Capacity	Total Water Tank Capacity
0.8 gal (3 L)	4.91 gal (18.6 L)	2.41 gal (9.1 L)	7.32 gal (27.7 L)

Fog Fluid Runtime (3L)	Fog Fluid Consumption	Water Runtime (27.7 L)	Water Consumption
2 hr	25 mL/min (0.88 fl.oz/min)	2.5 hr	184.7 mL/min (6.25 fl oz/min)

Thermal

Maximum External Temperature	Cooling System
113 °F (45 °C)	Fan-assisted Convection

DMX

I/O Connector	Channel Range
3-or 5-pin IP rated	3

Ordering

Product Name	Item Name	Item Code	UPC Number
Cloud 9X IP	Cloud 9X IP	05072617	781462229658
Cloud 9X IP 230V	220VCloud 9X IP	05072677	781462230258



Contact Us

General Information	Technical Support
Chauvet World Headquarters	
Address: 3360 Davie Rd., Suite 509 Davie, FL 33314 Voice: (954) 577-4455 Fax: (954) 929-5560 Toll Free: (800) 762-1084	Voice: (844) 393-7575 Fax: (954) 756-8015 Email: chauvetcs@chauvetlighting.com Website: www.chauvetprofessional.com
Chauvet U.K.	
Address: Pod 1 EVO Park Little Oak Drive, Sherwood Park Nottinghamshire, NG15 0EB UK Voice: +44 (0) 1773 511115 Fax: +44 (0) 1773 511110	Email: UKtech@chauvetlighting.eu Website: www.chauvetprofessional.eu
Chauvet Benelux	
Address: Vaartlaan 9 9800 Deinze Belgium Voice: +32 9 388 93 97	Email: BNLtech@chauvetlighting.eu Website: www.chauvetprofessional.eu
Chauvet France	
Address: 3, Rue Ampère 91380 Chilly-Mazarin France Voice: +33 1 78 85 33 59	Email: FRtech@chauvetlighting.fr Website: www.chauvetprofessional.eu
Chauvet Germany	
Address: Bruno-Bürgel-Str. 11 28759 Bremen Germany Voice: +49 421 62 60 20	Email: DEtech@chauvetlighting.de Website: www.chauvetprofessional.eu
Chauvet Mexico	
Address: Av. de las Partidas 34 - 3B (Entrance by Calle 2) Zona Industrial Lerma Lerma, Edo. de México, CP 52000 Voice: +52 (728) 690-2010	Email: servicio@chauvet.com.mx Website: www.chauvetprofessional.mx

Warranty & Returns

For warranty terms and conditions and return information, please visit our website.

For customers in the United States and Mexico: www.chauvetlighting.com/warranty-registration.

For customers in the United Kingdom, Republic of Ireland, Belgium, the Netherlands, Luxembourg, France, and Germany: www.chauvetlighting.eu/warranty-registration.